

# NG2012LS

## ASSEMBLY INSTRUCTION

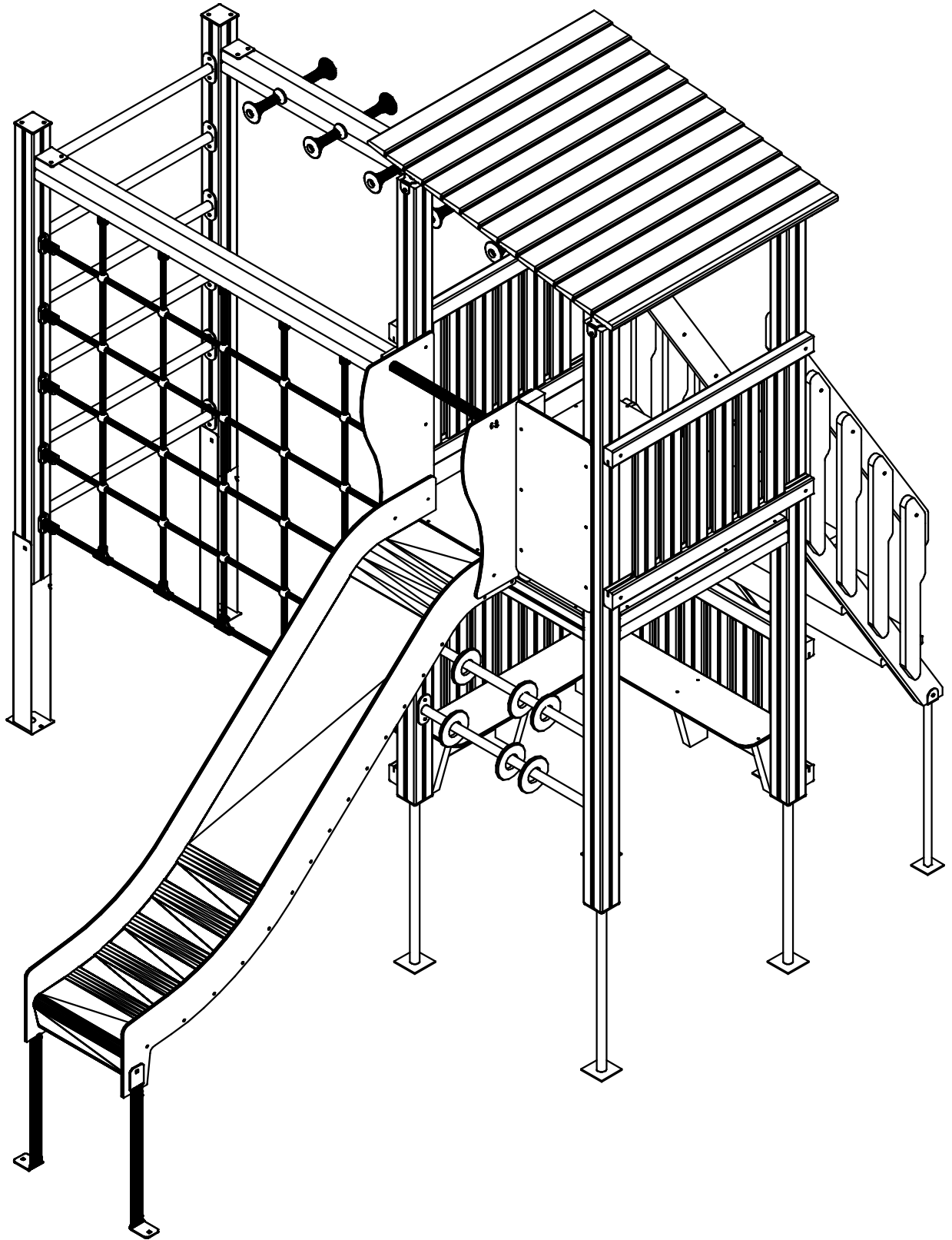

# KPLN DESIGN



## Instalation provisions / *Montāžas noteikumi*

Before equipment installing, read the information about the location of the play equipment, the requirements of the safety zone, the depth of the concrete, the choice of shock-absorbing surfaces, and the installation time.

Take into account the requirement of the safety zone (it must be at least 1,50 m around equipment which is higher 0,60 m, 2,50 m around equipment if the equipment is higher than 1,50 m), which are shown in the assembly instruction, see "Overview". Dangerous or traumatic objects, such as concrete supports, wooden stumps, and stones and other objects not related to playing /exercise are forbidden in this installation area. The equipment cannot be installed on a hard surface - concrete, asphalt surface, as well as on a slope if the angle of fall is bigger than 2°. It is not recommended to install equipment with too loose covering. When choosing the location of the equipment, pay attention to the direction of the sun, the sliding surface must not be in direct sunlight. Equipment must be leveled regardless of technical or natural considerations. The installation of the equipment and its elements is carried out in accordance with the assembly instructions. Detailed assembly steps are listed on the "Assembly steps" page. Each element has its own assembly instructions. Please follow the dimensions carefully.

Preparation of foundations are according to the requirements of the assembly instructions, see "Concreting - Digging". Make sure the foundation is stable. The thickness of the safety cover must be in accordance with the instructions given, see "Potential surface". The use of the device is allowed after 2 days when the concrete has completely hardened. The structures of the equipment are fastened with screwed metal foundations, using concrete casting at the installation site.

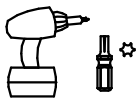
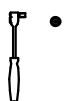
Check the equipment carefully by using the checklist. The area required for construction may increase in equipment installation time. Children are not allowed to participate in the installation work, as well as the use of the equipment is prohibited until it is fully installed, inspected and the safety zones are free of obstacles. The soil must be tramp after digging and installation work. Equipment safety and function tests are performed when the equipment is fully installed and earthworks are completed. Installation instructions are stored and documented in accordance with "Maintenance information".

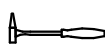
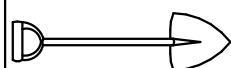
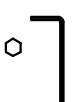
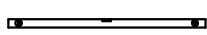
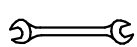
# Potencial surfaces / *Segumi*

Surface coating under the play equipment should be applied according to the En 1176-1:2017 standard.

*Segums zem rotaļu iekārtām jā'but saskaņā ar standartu LVS EN 1176-1:2018.*

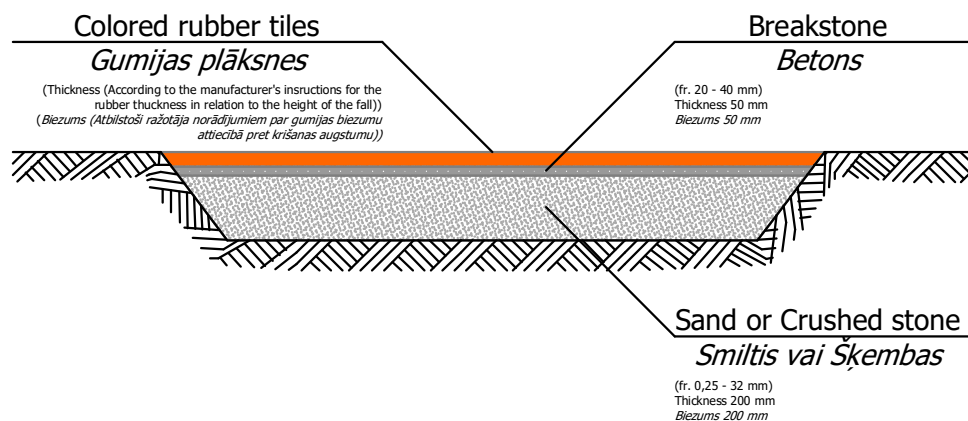
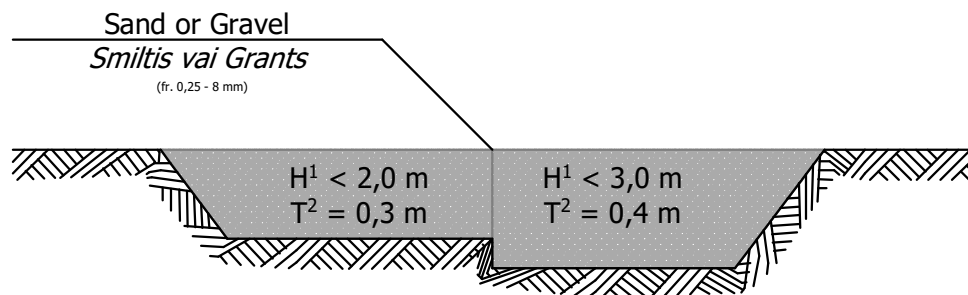
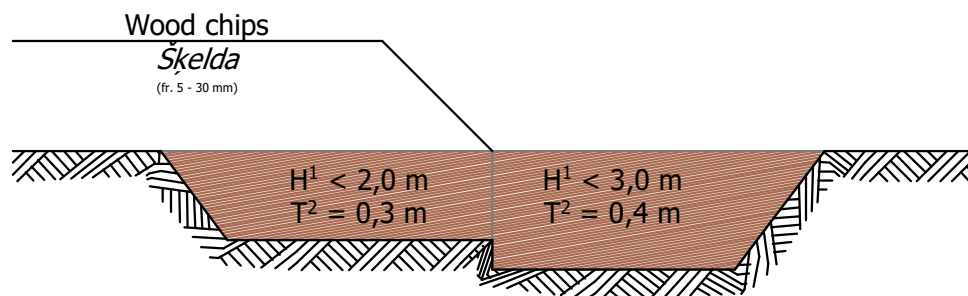
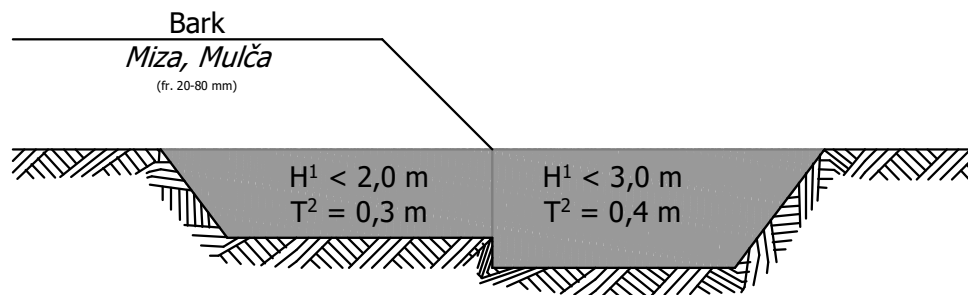
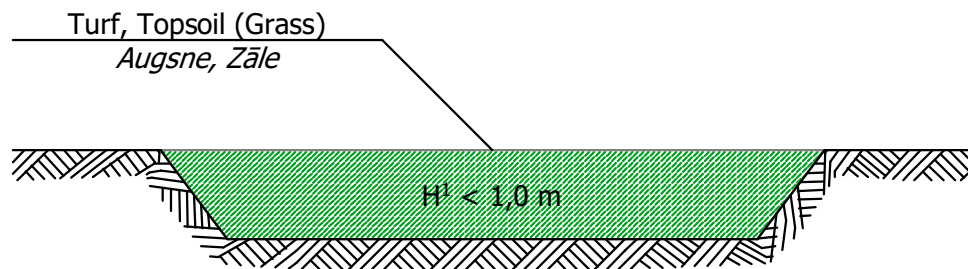

1 - Critical Height of Fall / *Krišanas augstums;*

2 - Loose Fill or Synthetic Surface Thickness / *Irdenā vai sintētiskā seguma biezums*

Equipment overview / Iekārtas kopskats

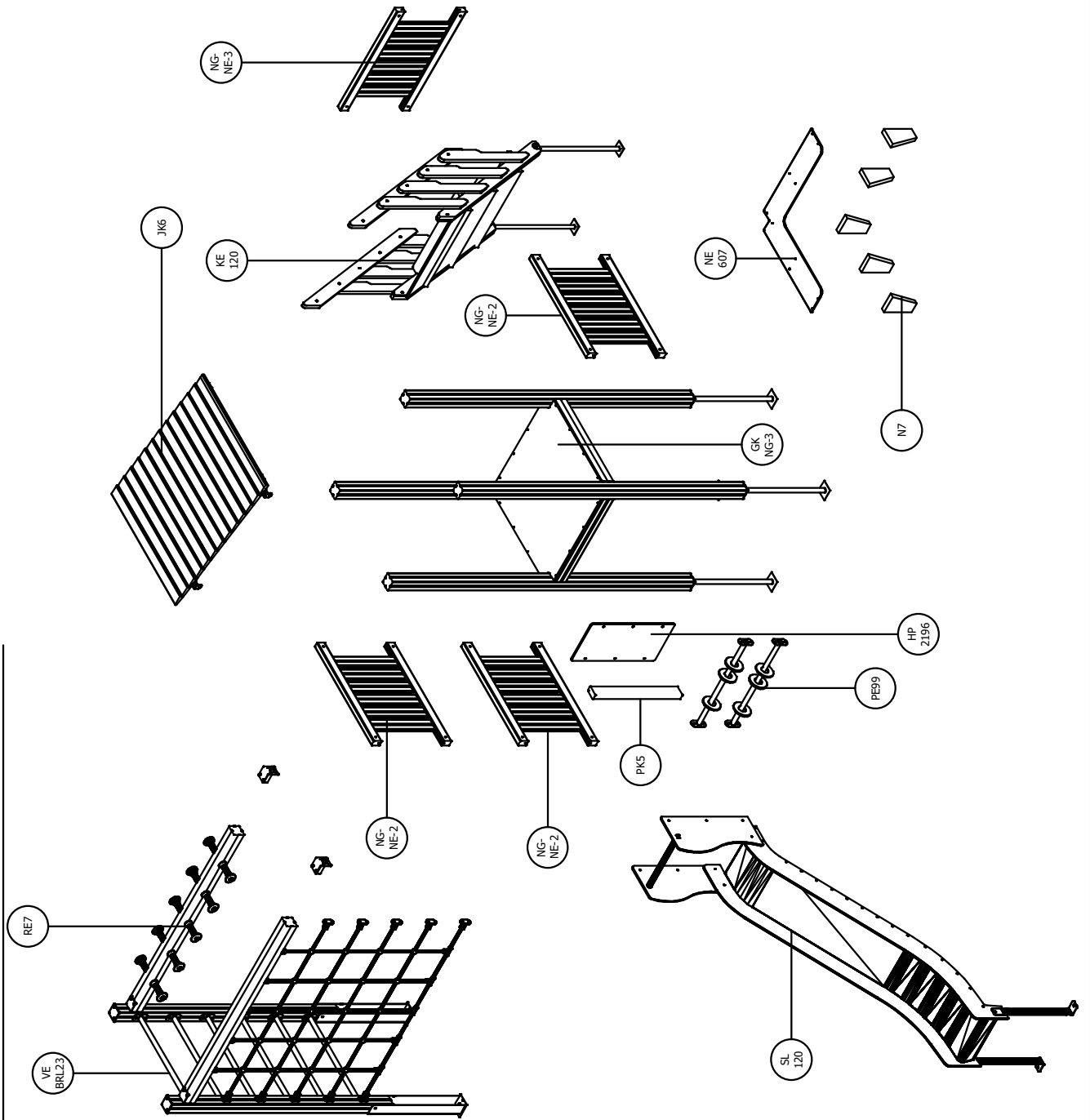

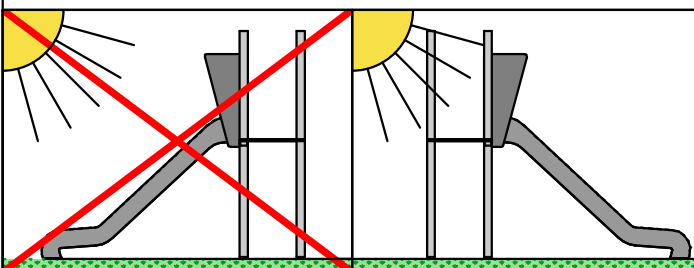
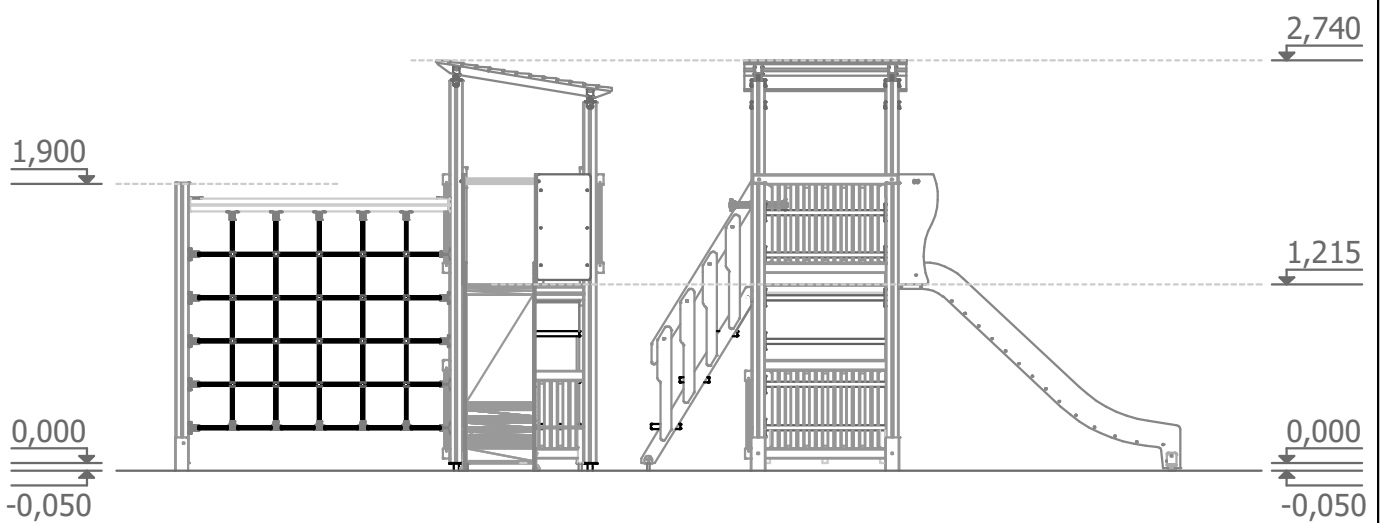
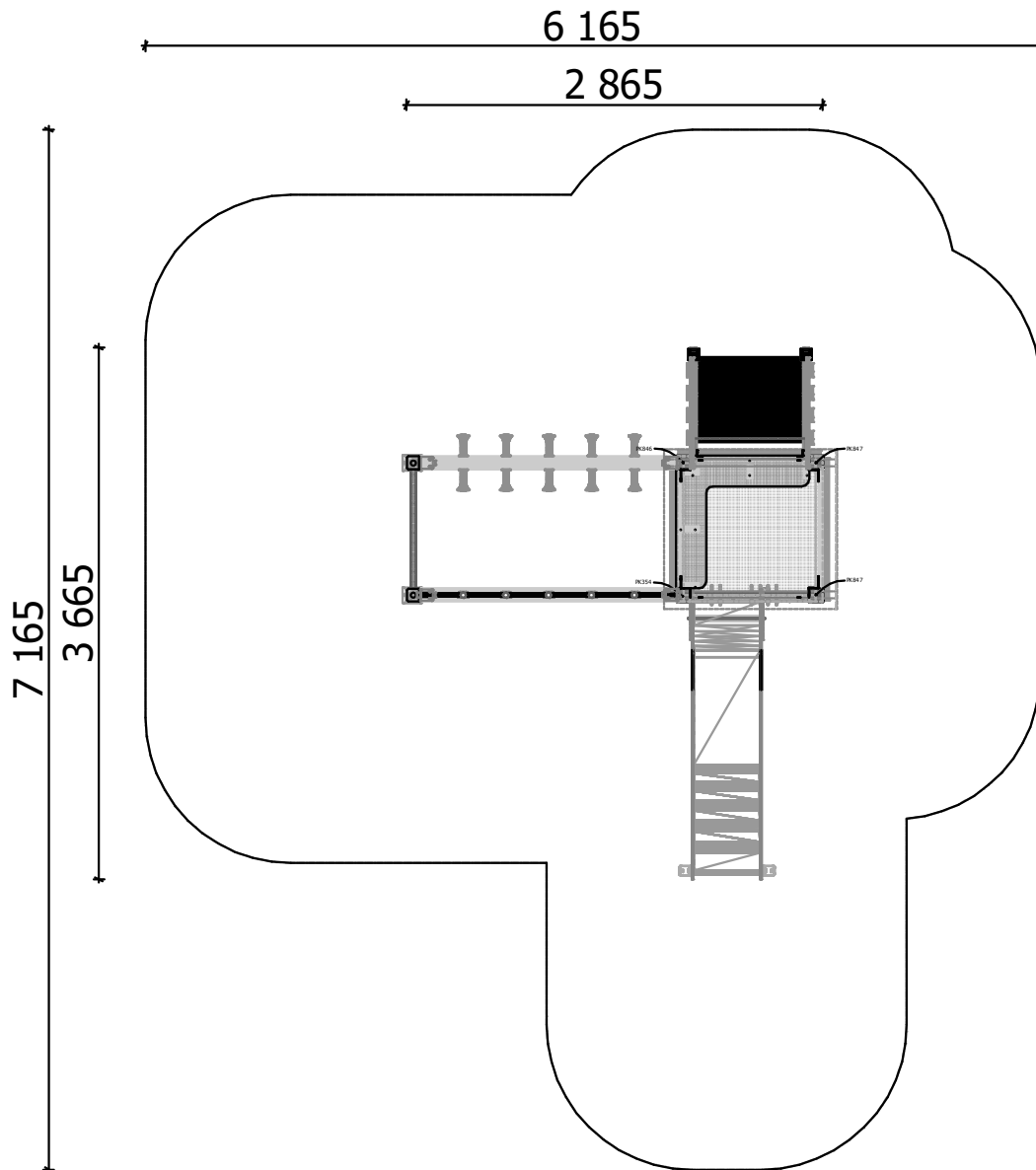

The slide should be positioned so, that the slope does not face south to reduce absorbed heat from the sun!

*Slidkalniņš jānovieto tā, lai slīdvirsmā nebūtu tiešā saules ietekmē!*

# Concreting - Digging / *Betoněšana - Rakšana*

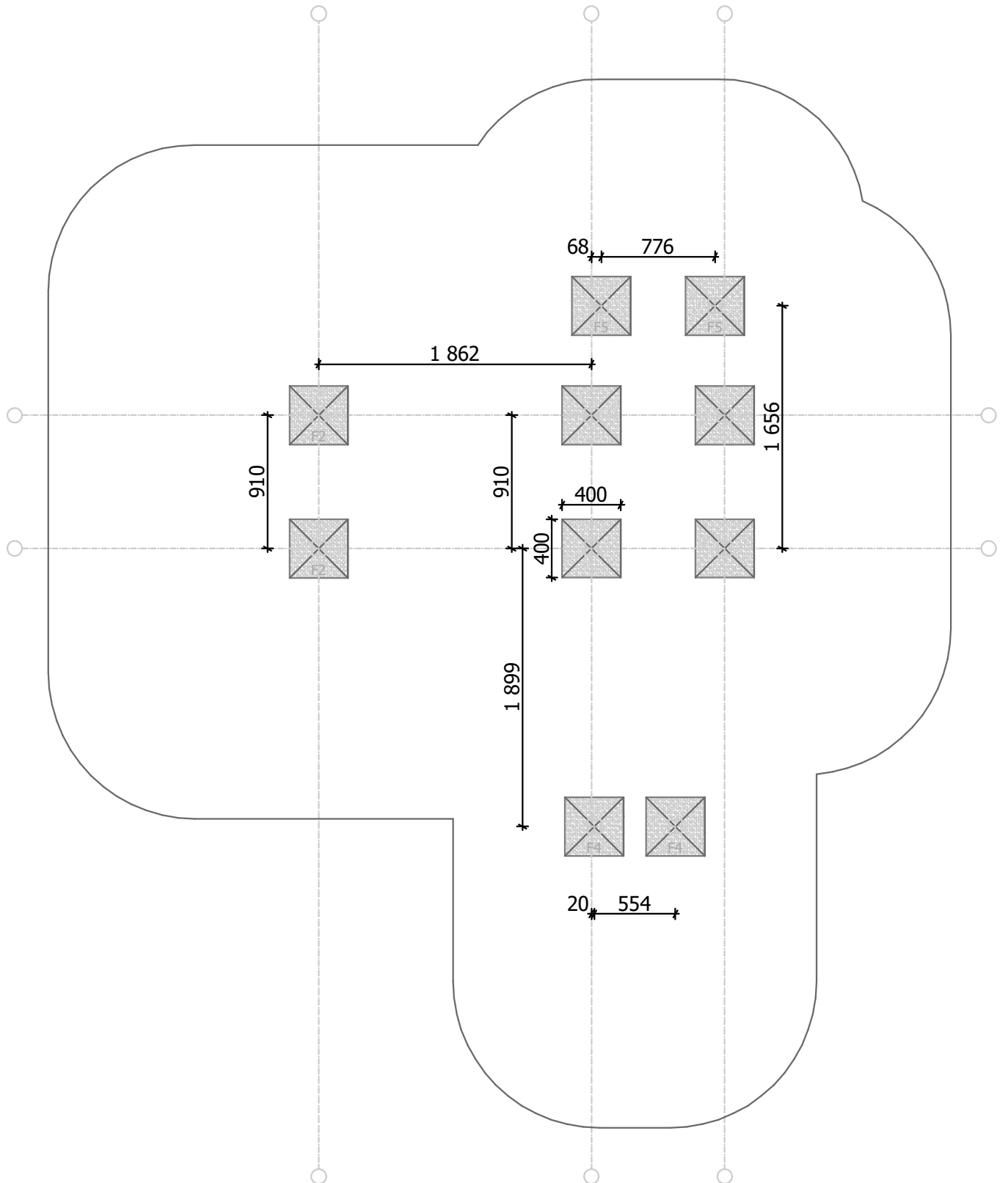

F1

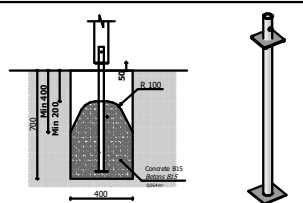

F2

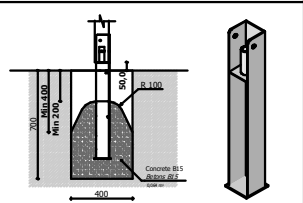



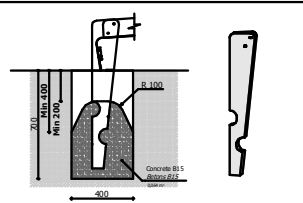



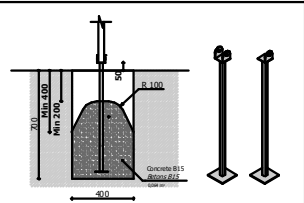

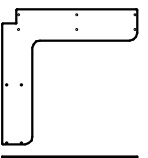

F4

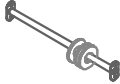
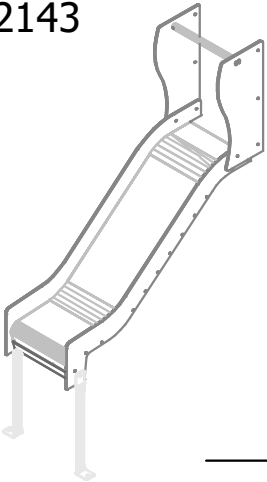
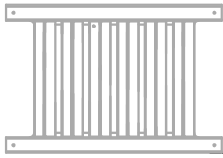
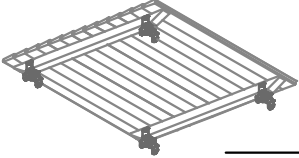
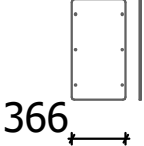
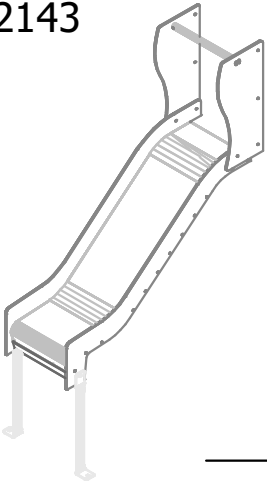
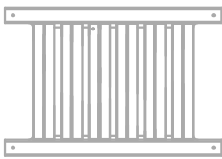
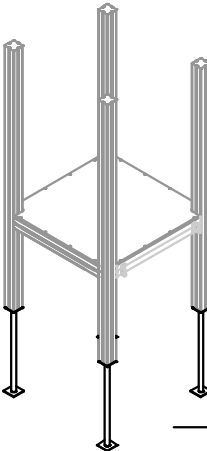
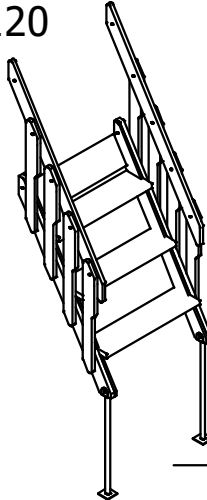
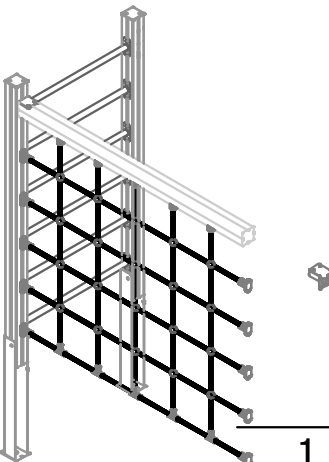

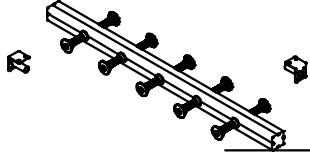
F5

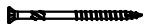
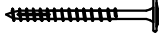
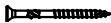

Specification / *Specifikācija*

<p>NE607</p>  <p>1</p>	<p>N7</p>  <p>5</p>	<p>PE99</p>  <p>2</p>	<p>X2143</p>  <p>1</p>
<p>NE_NG_3 H 600 mm</p>  <p>1</p>	<p>JK6</p>  <p>1</p>	<p>HP2196</p>  <p>366</p> <p>1</p>	 <p>1</p>
<p>NE-NG-2 H 670 mm</p>  <p>3</p>	<p>GK-NG-3</p>  <p>1</p>	<p>KE120</p>  <p>1</p>	<p>VEBRL</p>  <p>1</p>
<p>PK5</p>  <p>750</p> <p>1</p>			
<p>RE7</p>  <p>1</p>			
<p>14 8 x 50</p>  <p>6</p>	<p>10 8 x 40</p>  <p>8</p>	<p>25 6 x 90</p>  <p>1</p>	<p>11 8 x 80</p>  <p>24</p>
<p>8 5 x 70</p>  <p>8</p>	<p>21</p>  <p>10</p>	<p>16 2,9 x 16 (22)</p>  <p>2</p>	<p>00</p>  <p>1</p>

# Detail steps / Montāžas soļi

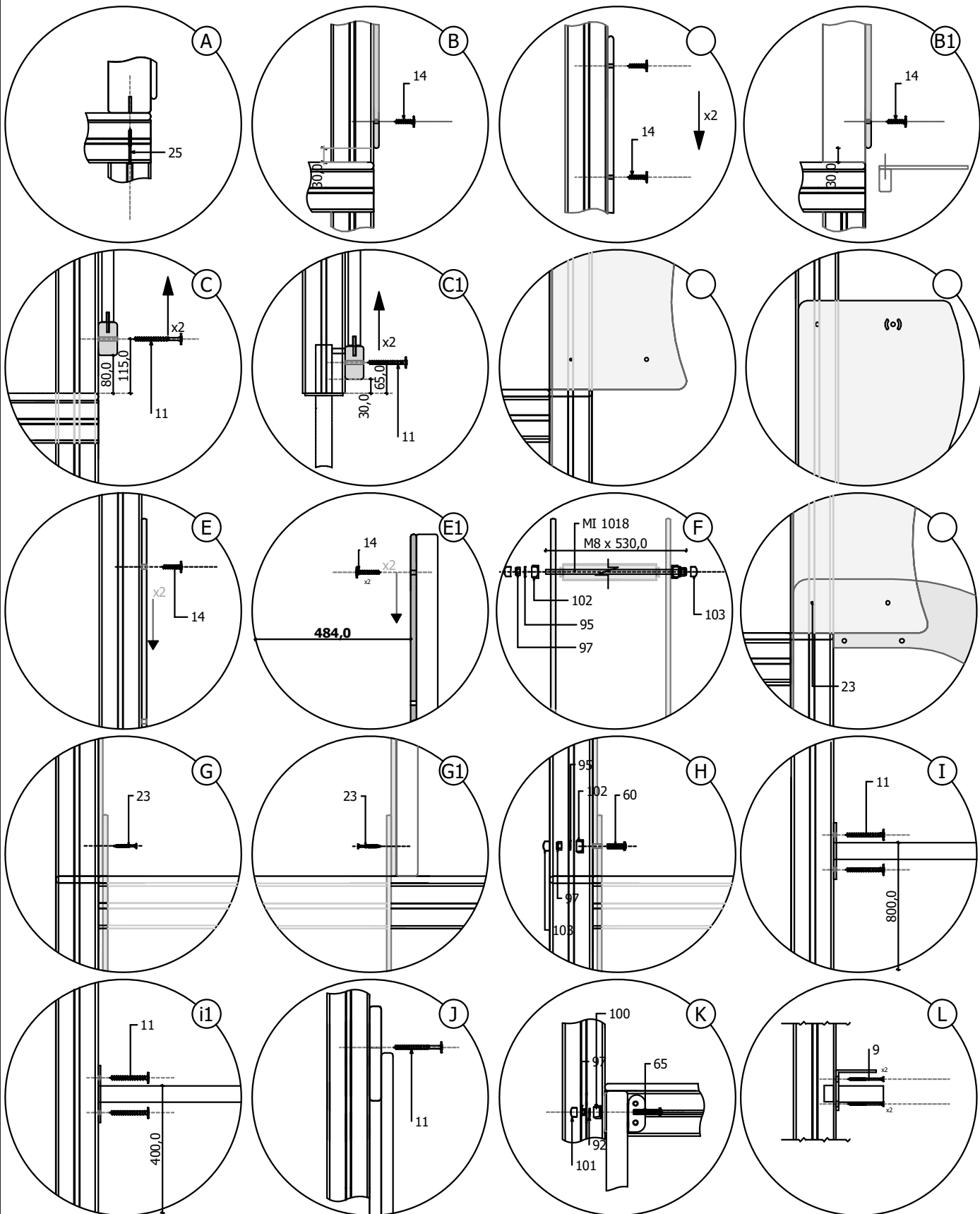



Detail steps / *Montāžas soļi*

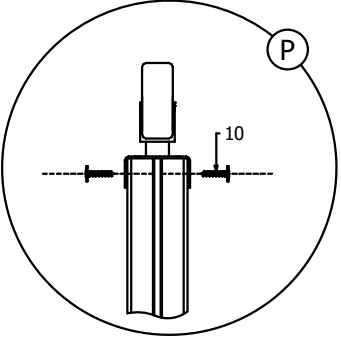
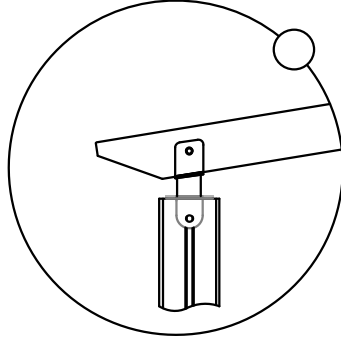
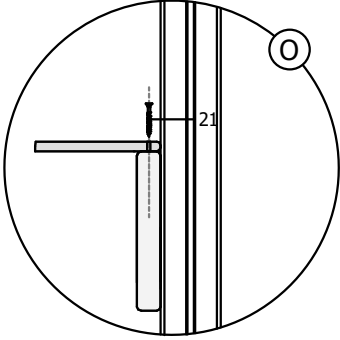
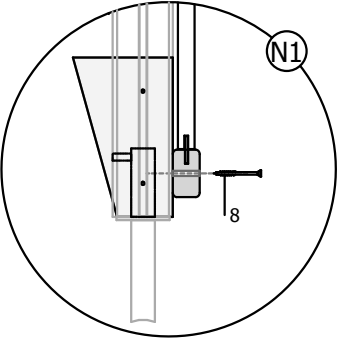
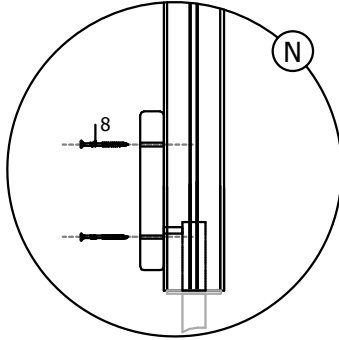
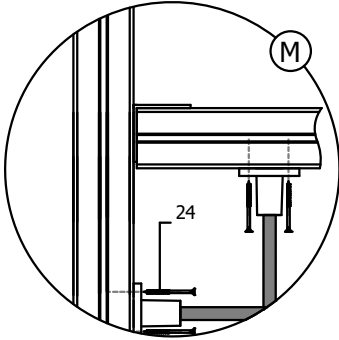
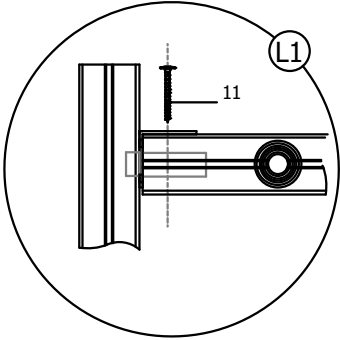

# 1

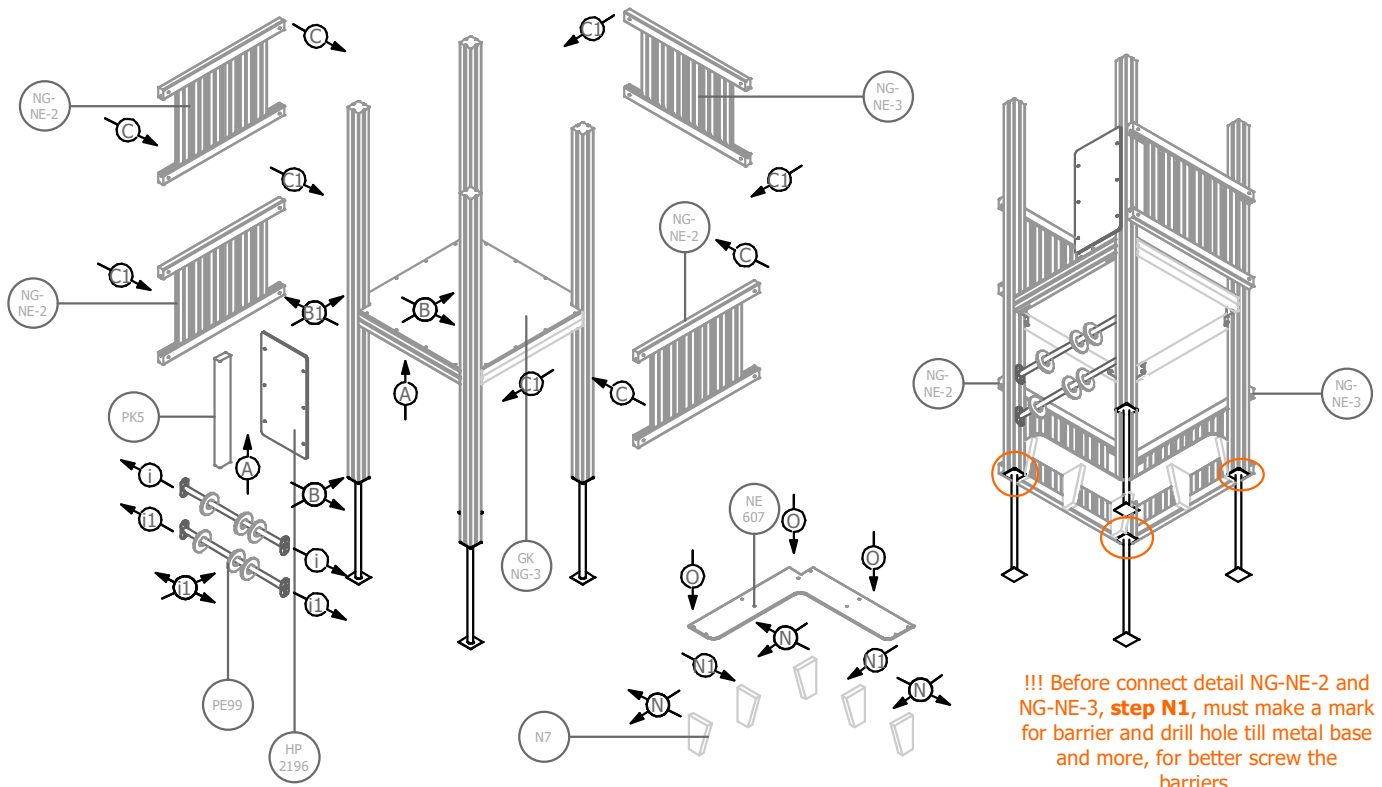

!!! Before connect detail NG-NE-2 and NG-NE-3, **step N1**, must make a mark for barrier and drill hole till metal base and more, for better screw the barriers.

# 2

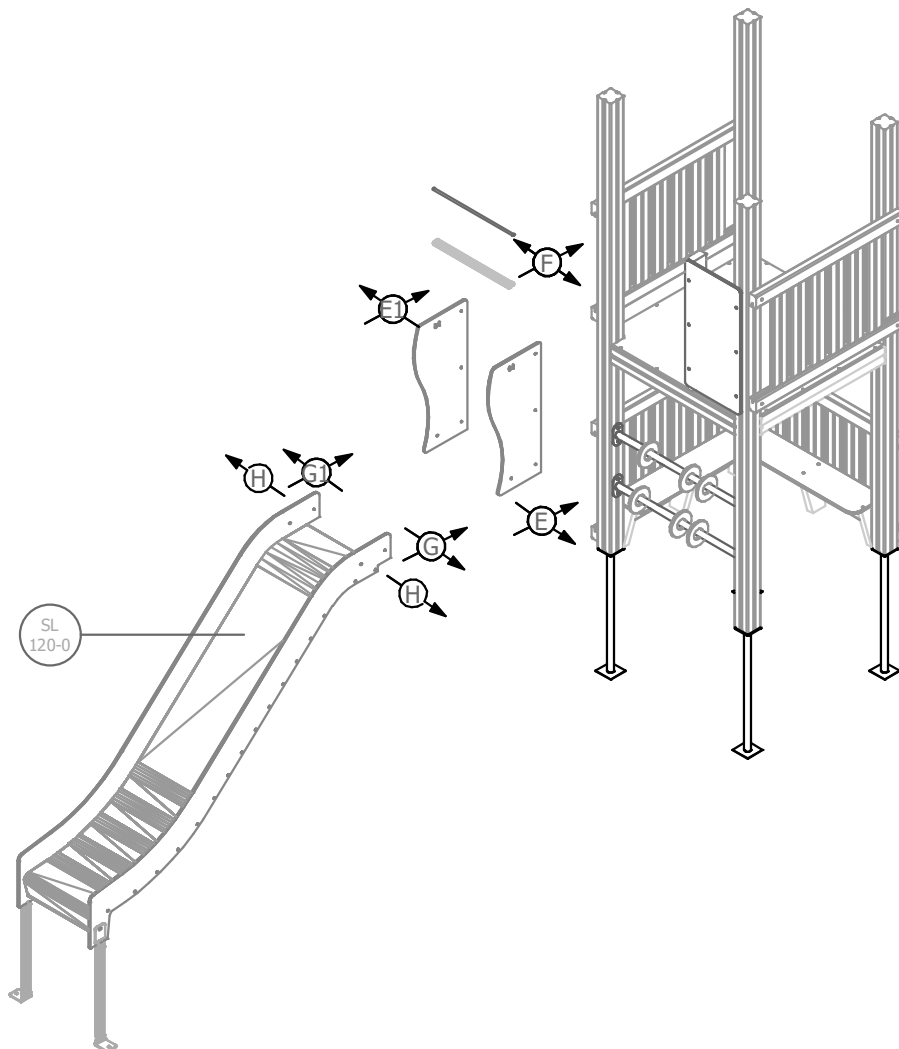

3

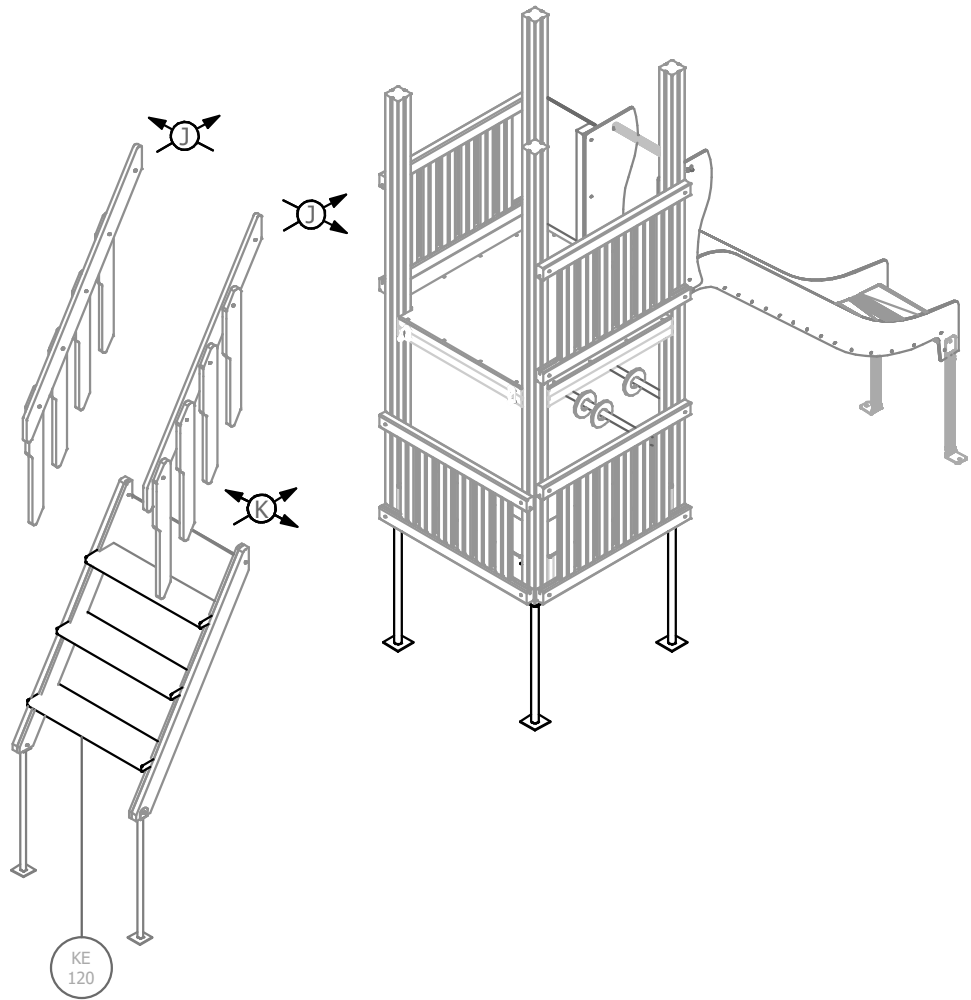

4

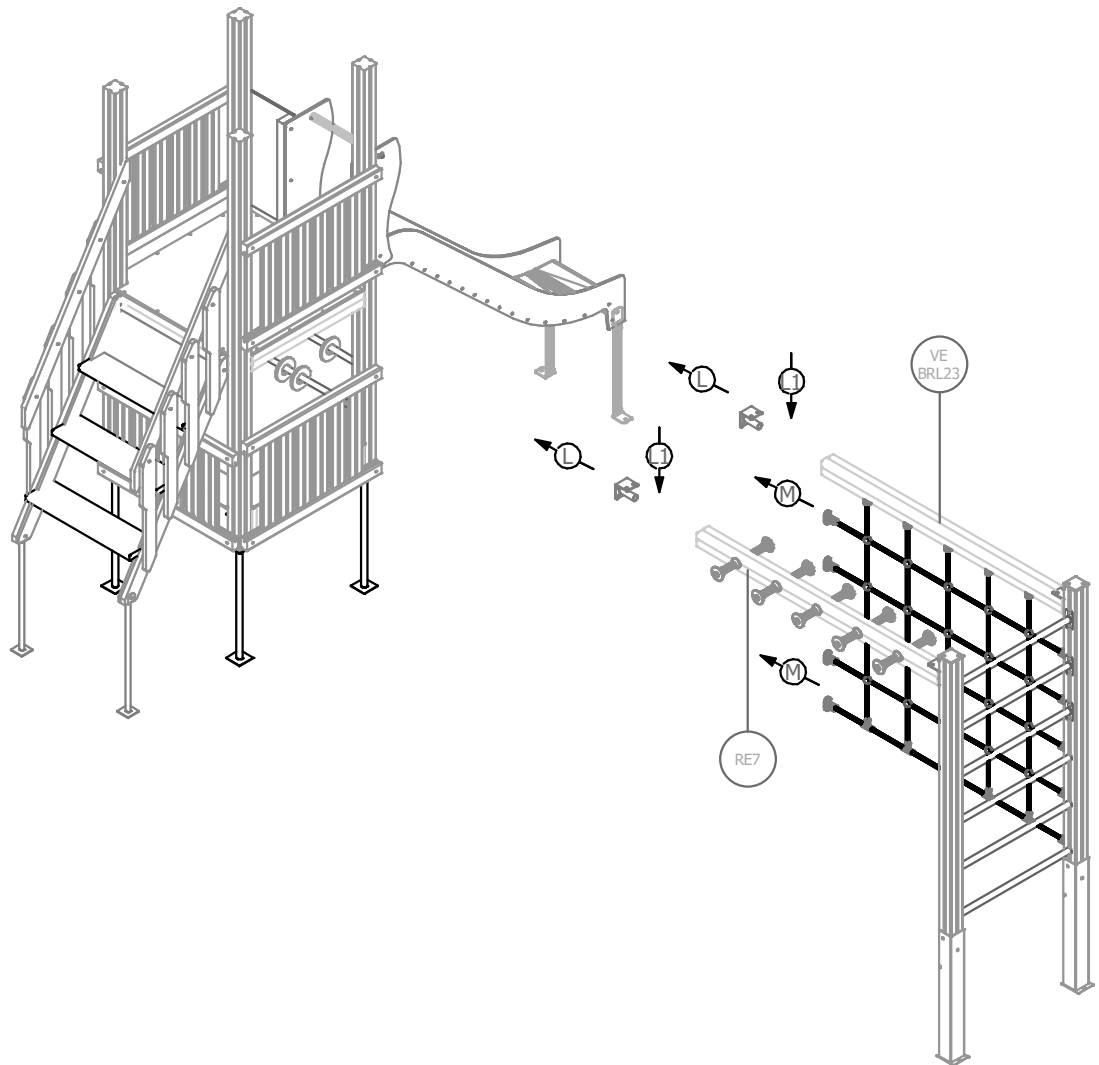

5

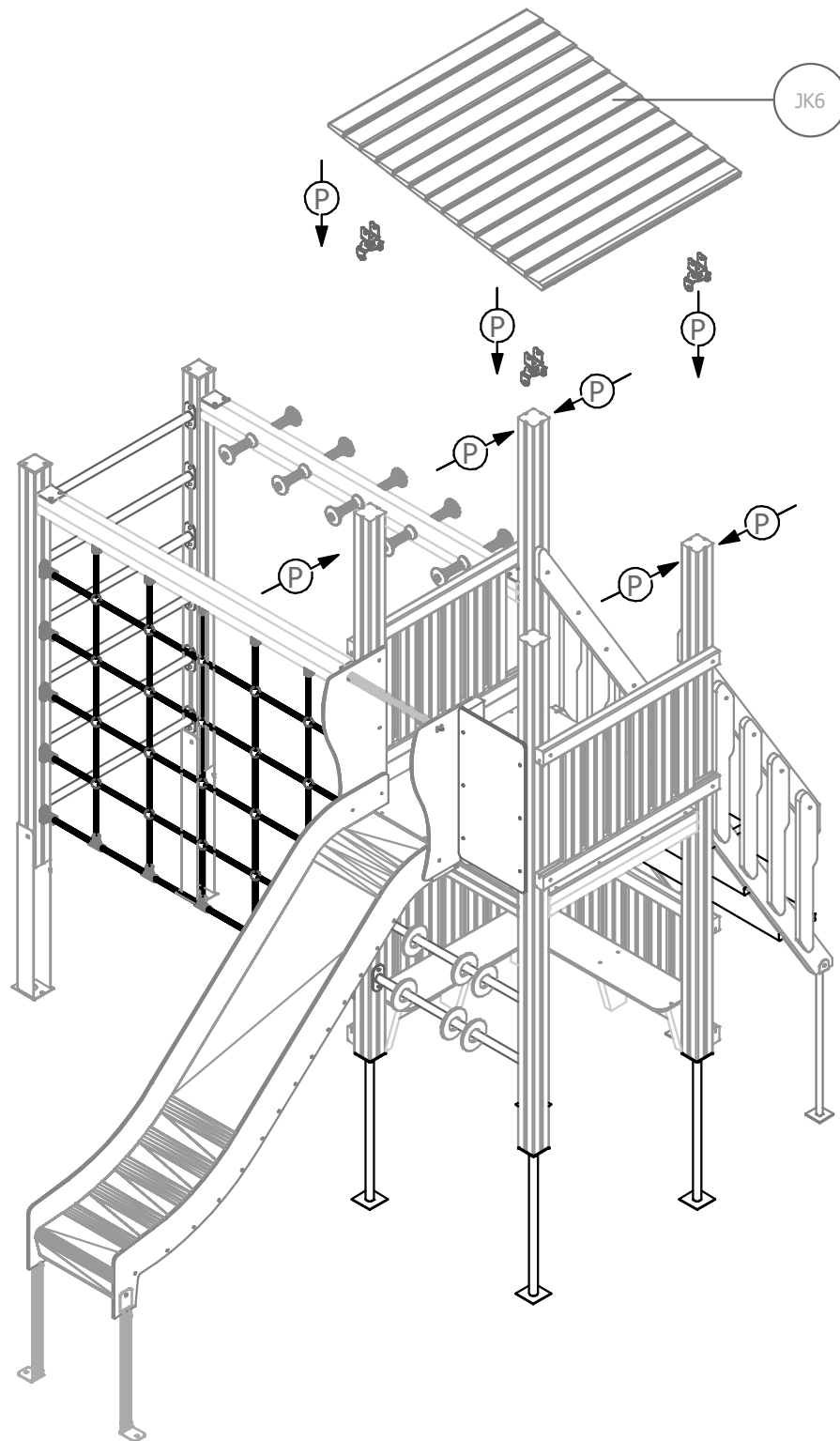

It is recommended to re-screw the platform floor after complete screwing of the playground equipment. Check that the gaps are formed between the edges of the beam and the floor. It is recommended to re-screw the all screws, bolts or other connecting points, specially if equipment was transported in big screwed parts.

*Ir ieteicams, pēc rotaļu kompleksa pilnīgas saskrūvēšanas, veikt platformas grīdas pārskrūvēšanu. Pārbaudīt, vai atstarpes starp brucas malām un grīdas ārmalām ir vienādas.*

*Ir ieteicams pārbaudīt visas stiprinājuma vietas - skrūvju, bultu un cita veida vietas - īpaši, ja iekārta ir transportēta elementu veidā.*

# GK-NG-3



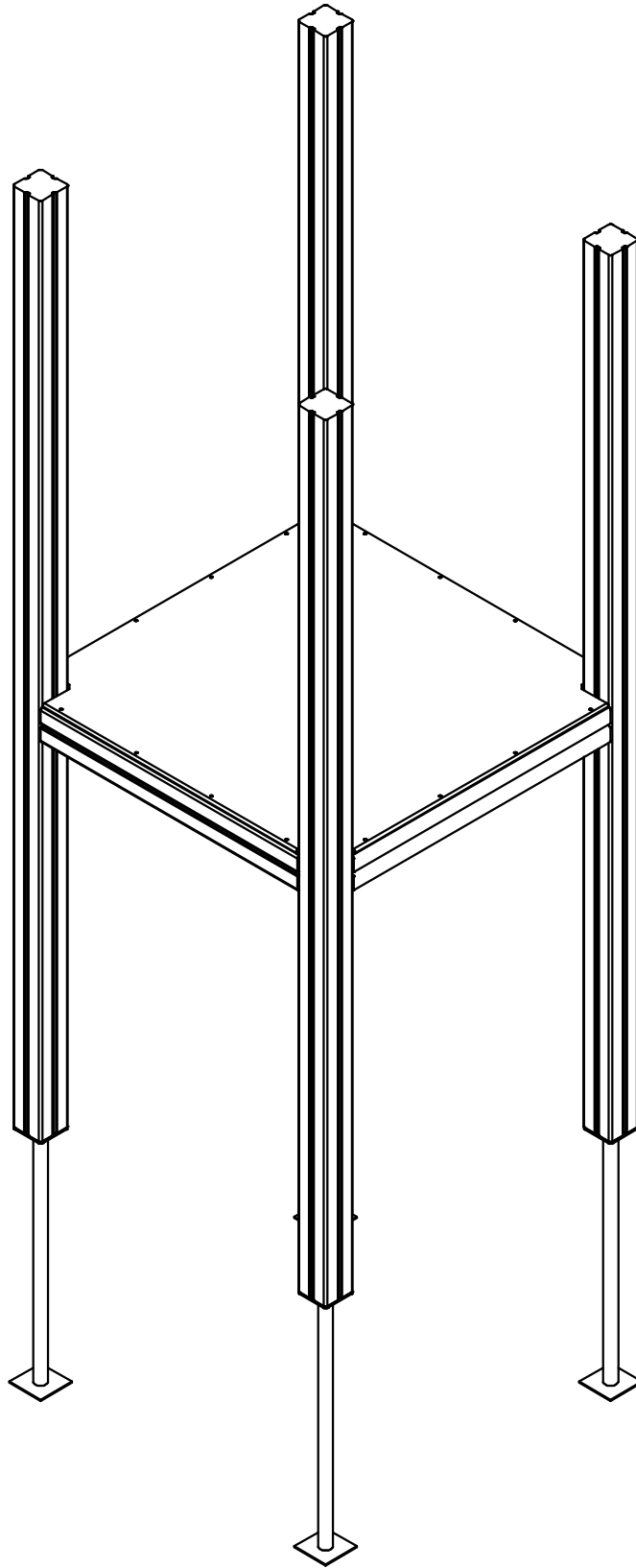



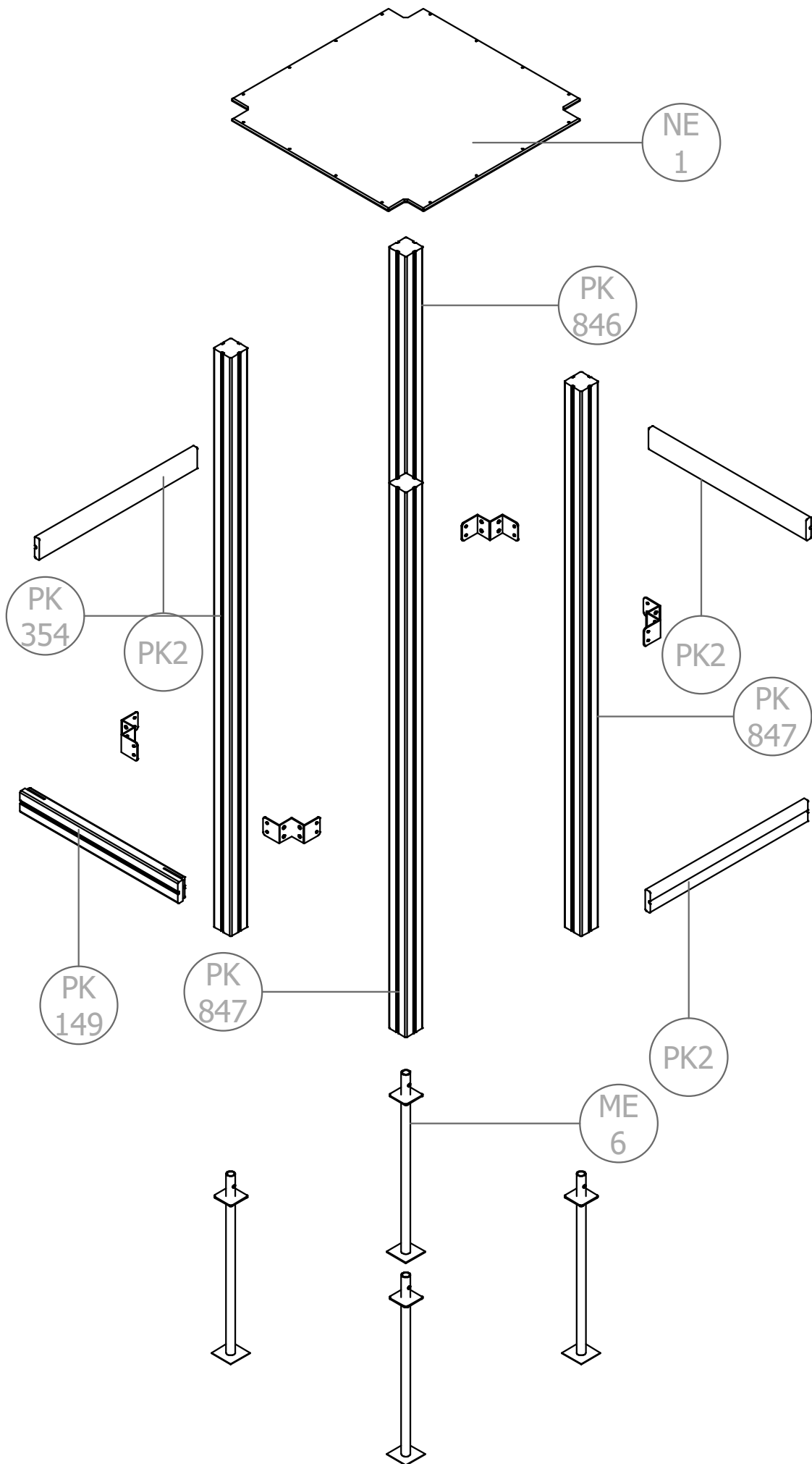



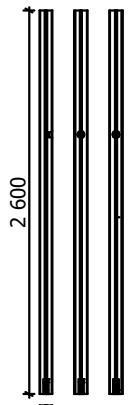

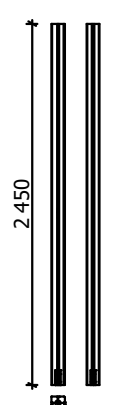
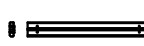
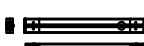
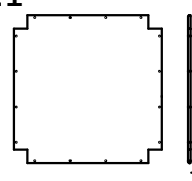
## ASSEMBLY INSTRUCTION

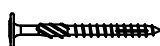

# KPLN DESIGN

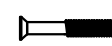

Specification / *Specifikācija*

<p>PK354</p>  <p style="text-align: right;">1</p>	<p>PK846</p>  <p style="text-align: right;">1</p>	<p>PK847</p>  <p style="text-align: right;">2</p>	<p>PK2</p>  <p style="text-align: right;">3</p> <hr/> <p>PK149</p>  <p style="text-align: right;">1</p>
<p>NE1</p>  <p style="text-align: right;">1</p>			<p>ME4</p>  <p style="text-align: right;">4</p>
<p>10</p> <p style="text-align: right;">8 x 40</p>  <p style="text-align: right;">16</p>	<p>13</p> <p style="text-align: right;">10 x 80</p>  <p style="text-align: right;">4</p>	<p>20</p> <p style="text-align: right;">5 x 50</p>  <p style="text-align: right;">16</p>	<p>ME6</p>  <p style="text-align: right;">4</p>
<p>61</p> <p style="text-align: right;">8 x 40</p>  <p style="text-align: right;">12</p>	<p>65</p> <p style="text-align: right;">8 x 60</p>  <p style="text-align: right;">3</p>	<p>51</p> <p style="text-align: right;">8 x 60</p>  <p style="text-align: right;">1</p>	
<p>92</p>  <p style="text-align: right;">16</p>	<p>97</p>  <p style="text-align: right;">16</p>	<p>100</p>  <p style="text-align: right;">16</p>	<p>101</p>  <p style="text-align: right;">16</p>

# Detail steps / Montāžas soļi

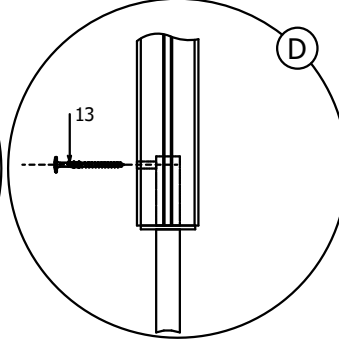
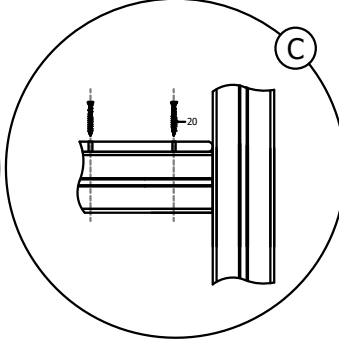
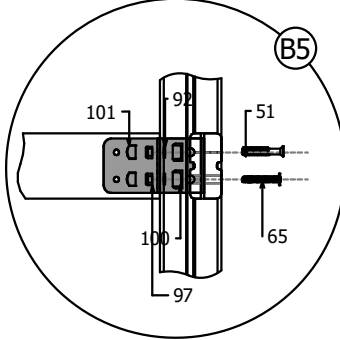
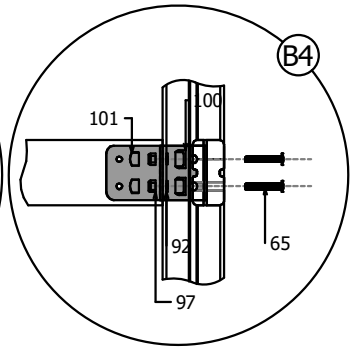
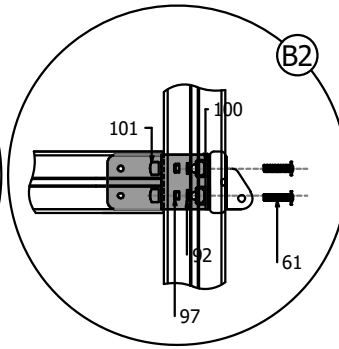
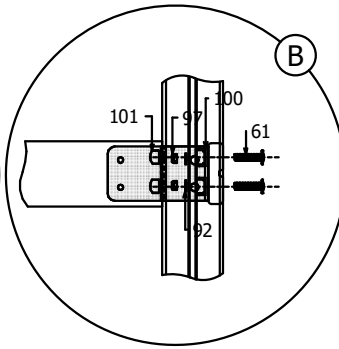
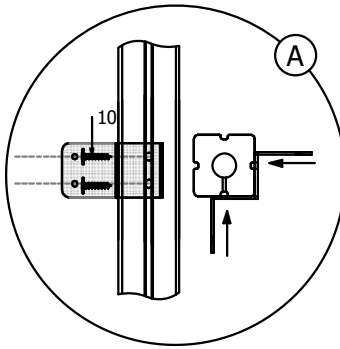



1

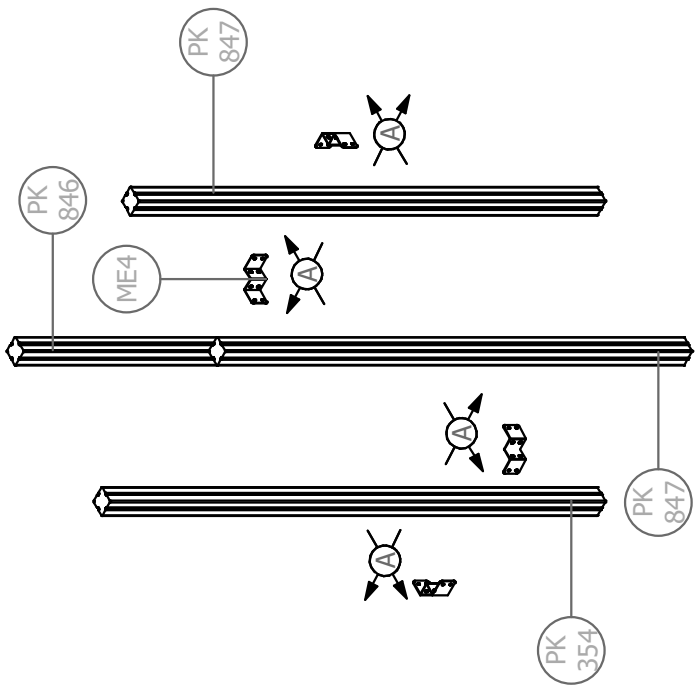

2

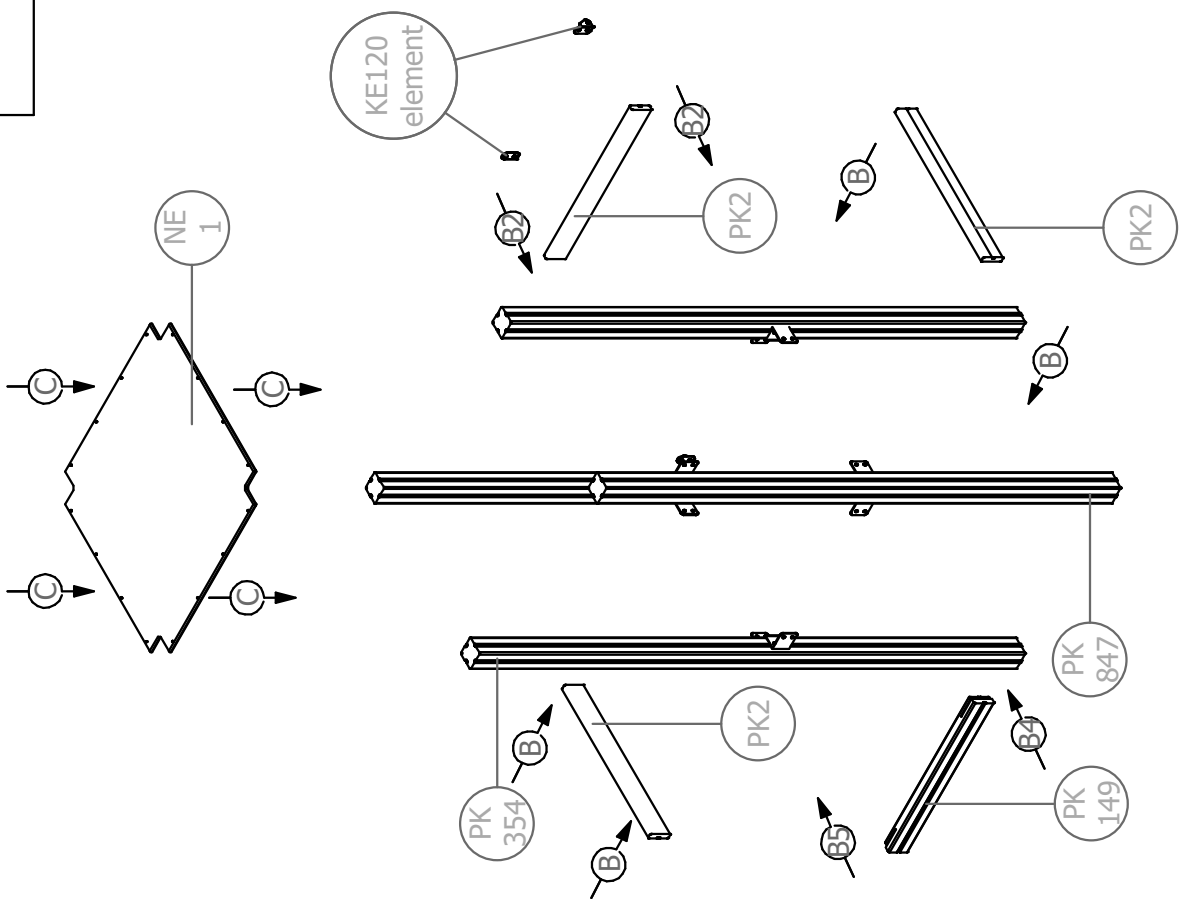

3

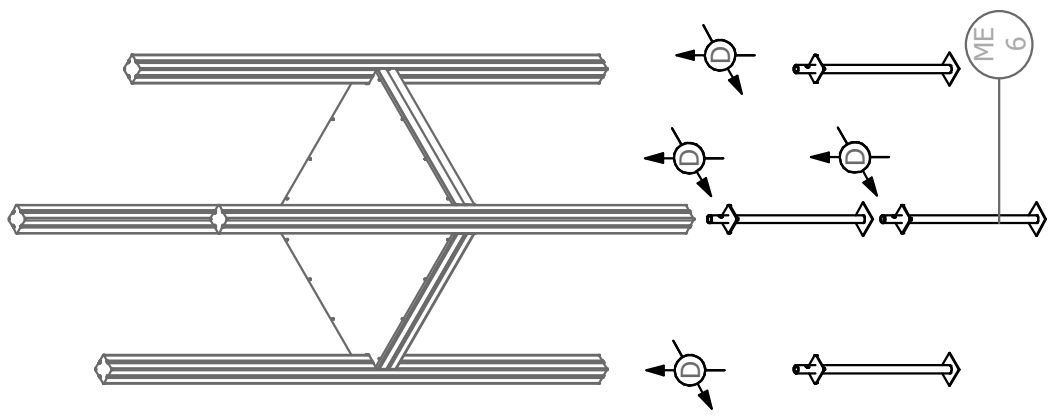

# VEBRL

## ASSEMBLY INSTRUCTION

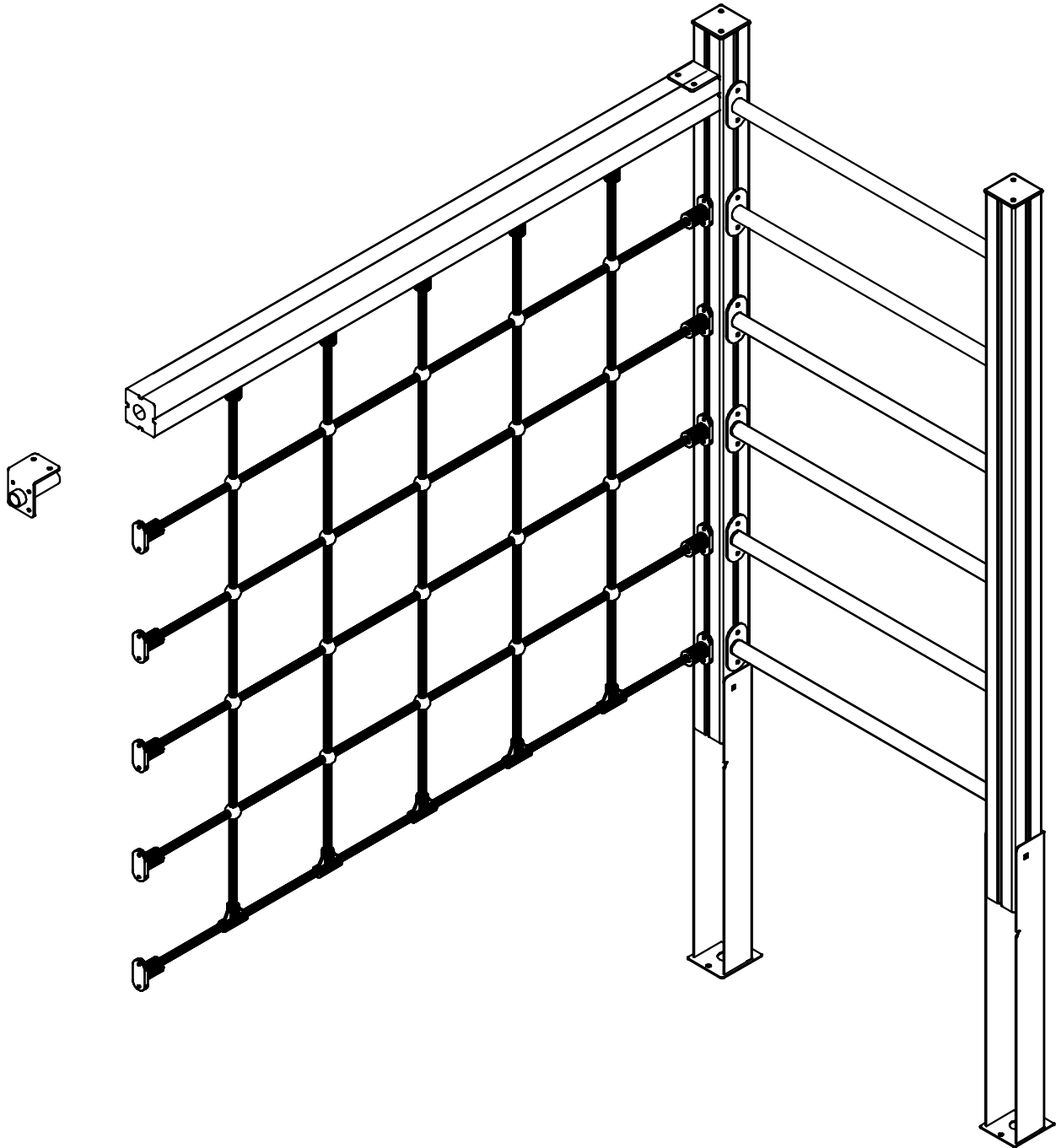





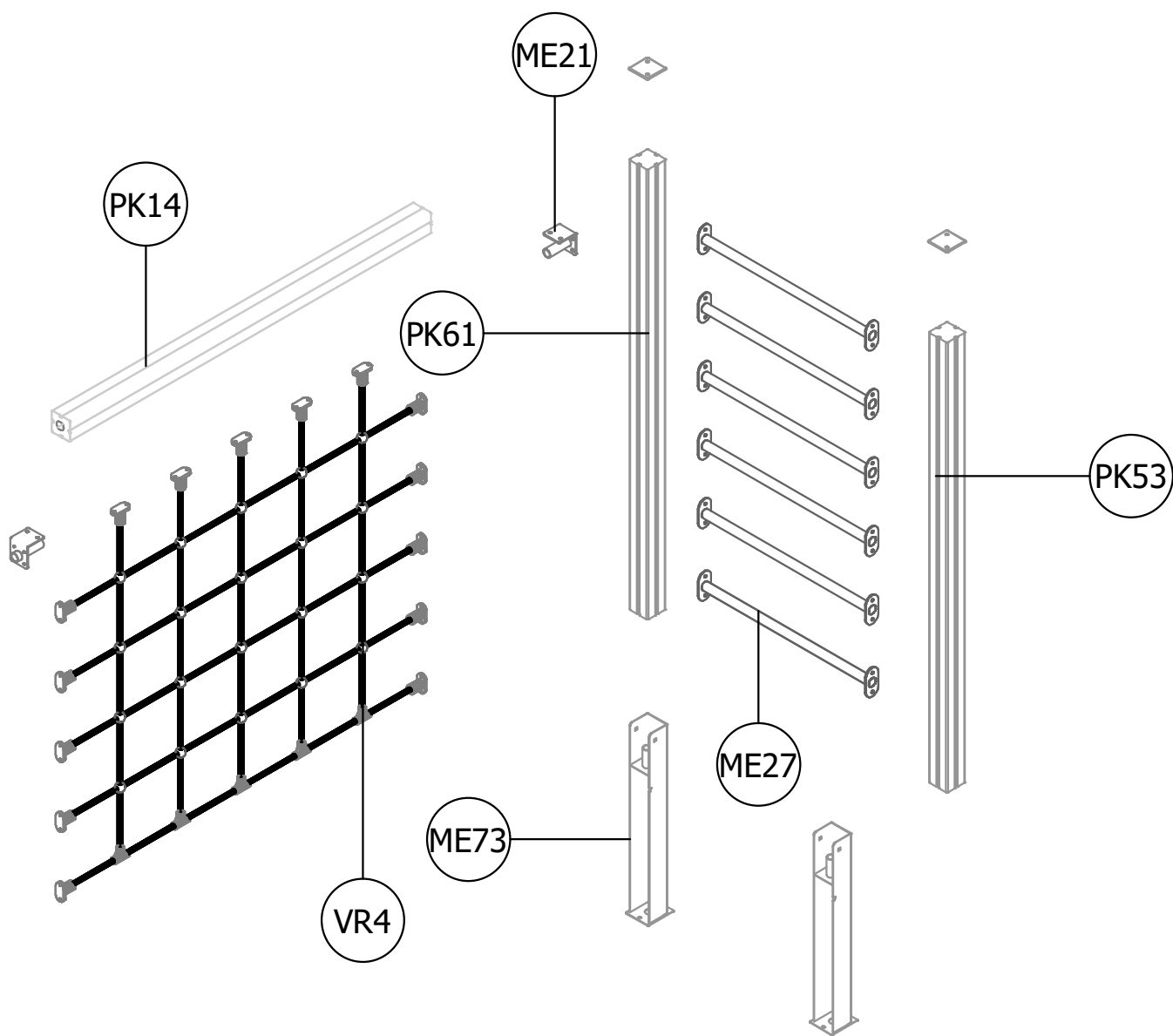

# KPLN DESIGN

Specification / *Specifikācija*

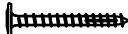

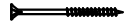
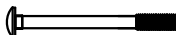
<p><b>PK61</b></p> <p>1900</p> <p>1</p>	<p><b>PK53</b></p> <p>1900</p> <p>1</p>	<p><b>VR4</b></p> <p>1</p>	<p><b>PK14</b></p> <p>1760</p> <p>1</p> <p><b>ME21</b></p> <p>2</p>
<p><b>NE351</b></p> <p>2</p>		<p><b>ME27</b></p> <p>6</p>	<p><b>ME73</b></p> <p>2</p>

Specification / *Specifikācija*

9  8	11  28	23  4	24  30
70  4	96  4	99  4	102  4
103  4			

Detail steps / *Montāžas soli*

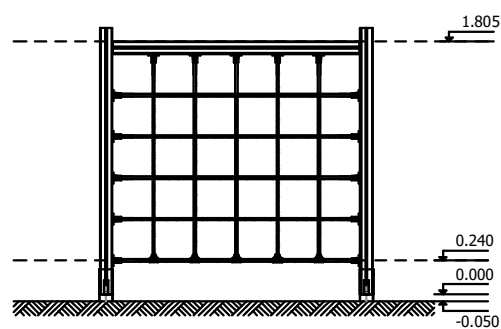
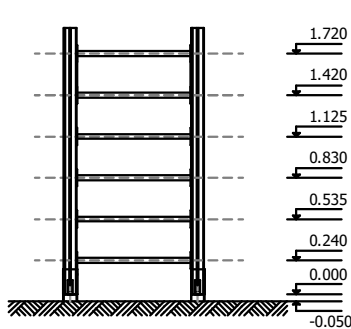
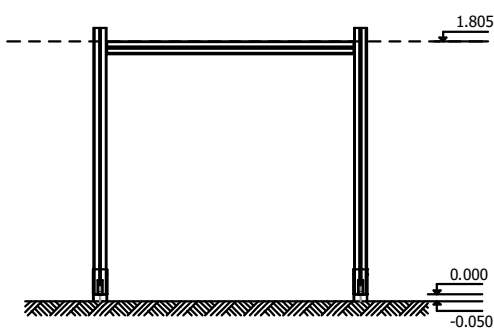
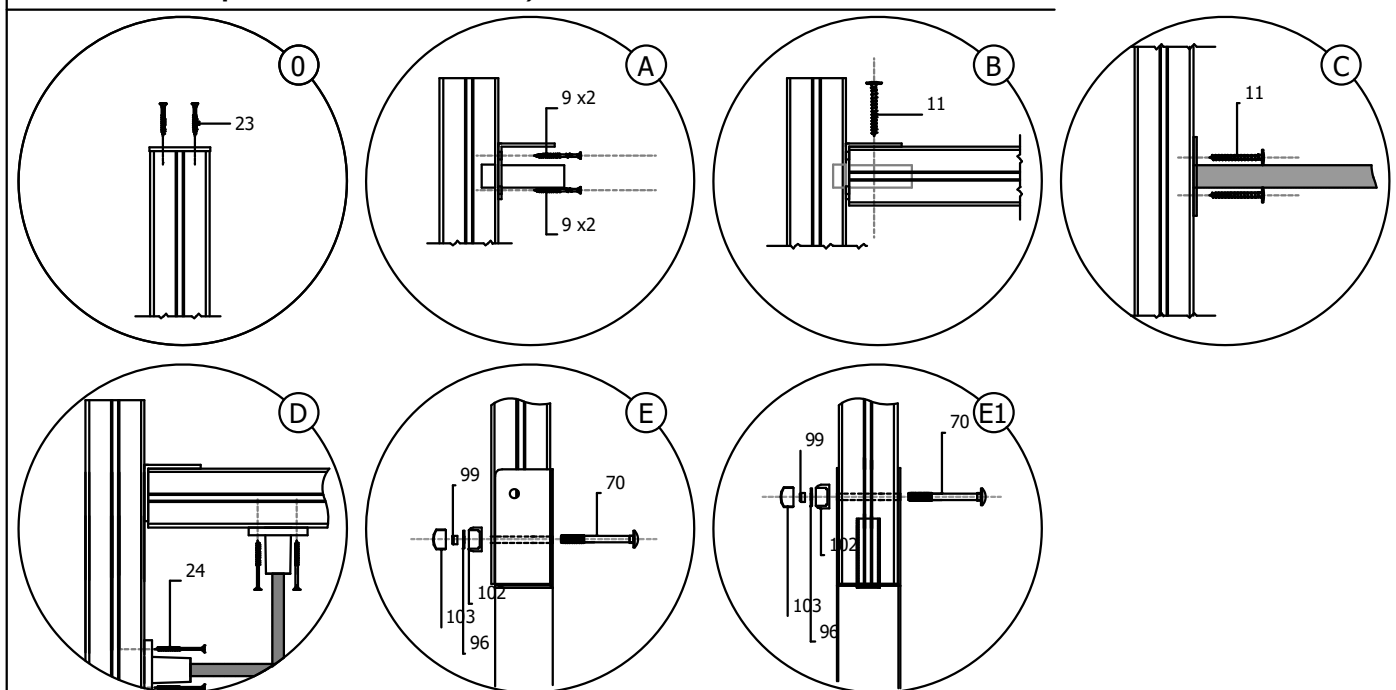

1

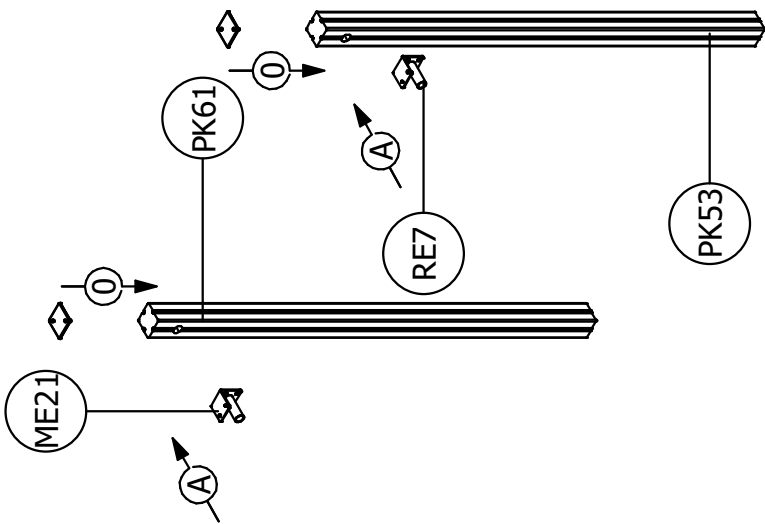

2

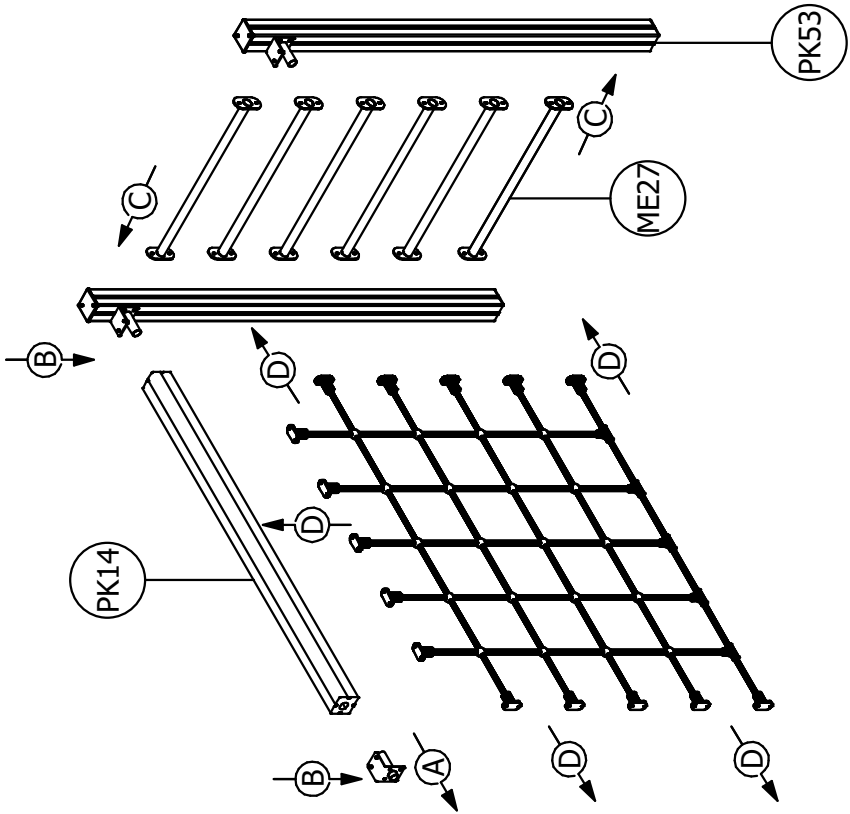

3

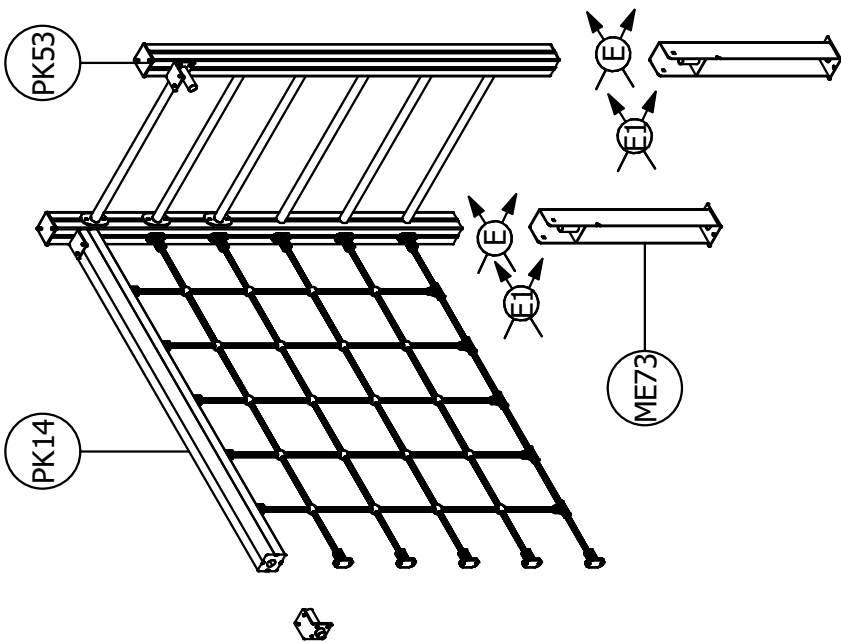

# X2142-E



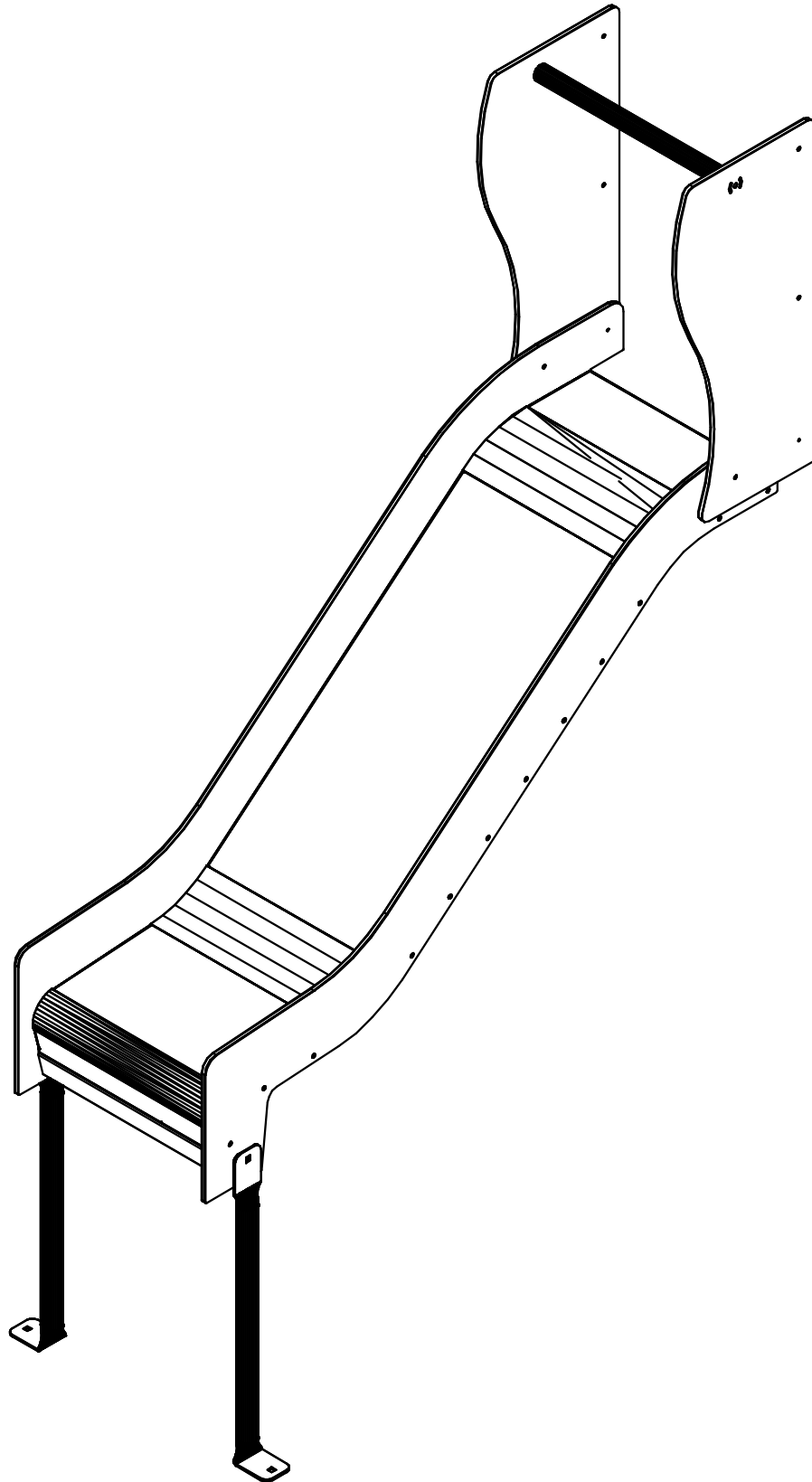



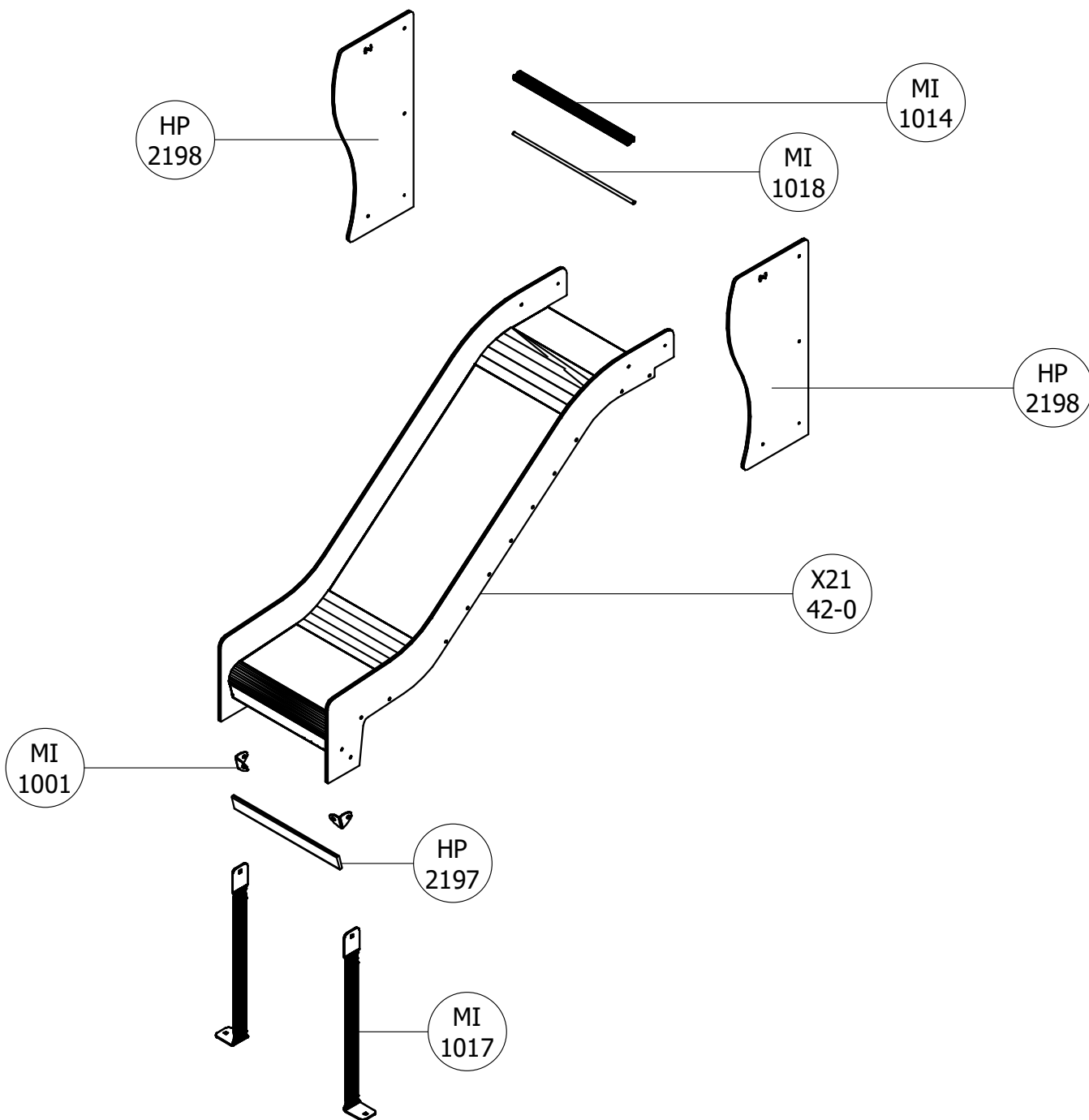



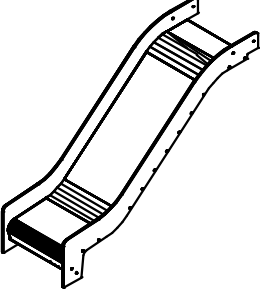







## ASSEMBLY INSTRUCTION



# KPLN DESIGN



Specification / *Specifikācija* / *Osaluettelo*

<p>X2142-0 <small>slide80</small></p>  <p style="text-align: right;">1</p>	<p>HP2198 <small>lpl</small></p>  <p style="text-align: right;">2</p>	<p>HP2197 <small>lpl</small></p>  <p style="text-align: right;">1</p>	<p>MI1001</p>  <p style="text-align: right;">2</p>
		<p>MI1014</p>  <p style="text-align: right;">1</p>	
<p>60 <small>8 x 35</small></p>  <p style="text-align: right;">2</p>	<p>14 <small>8 x 50</small></p>  <p style="text-align: right;">2</p>	<p>23 <small>5 x 50</small></p>  <p style="text-align: right;">2</p>	<p>MI1017</p>  <p style="text-align: right;">2</p>
<p>92</p>  <p style="text-align: right;">2</p>	<p>169 <small>8 x 25</small></p>  <p style="text-align: right;">2</p>	<p>236 <small>8 x 30</small></p>  <p style="text-align: right;">2</p>	<p>MI1018</p>  <p style="text-align: right;">1</p>
<p>101</p>  <p style="text-align: right;">2</p>	<p>95</p>  <p style="text-align: right;">4</p>	<p>97</p>  <p style="text-align: right;">7</p>	<p>100</p>  <p style="text-align: right;">2</p>
	<p>102</p>  <p style="text-align: right;">4</p>	<p>103</p>  <p style="text-align: right;">4</p>	



# Detail steps / *Montāžas soli* / *Asennusvaiheet*

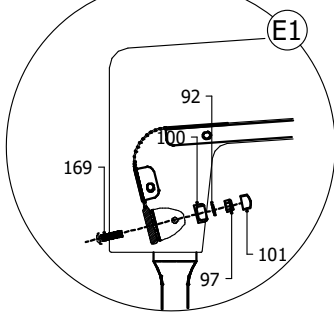
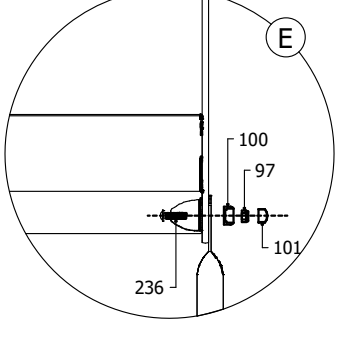
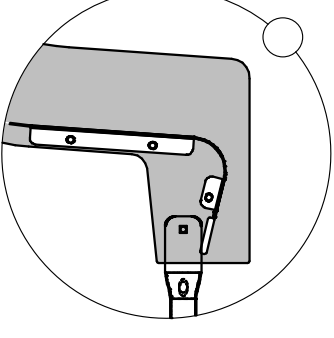
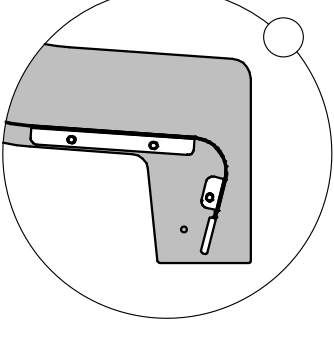
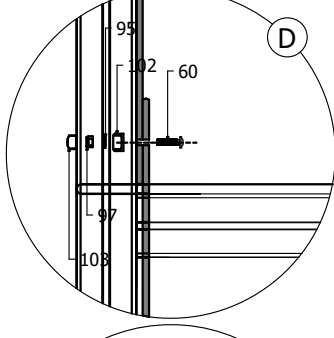
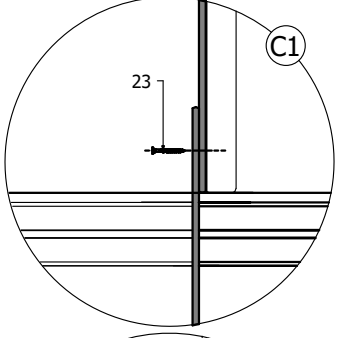
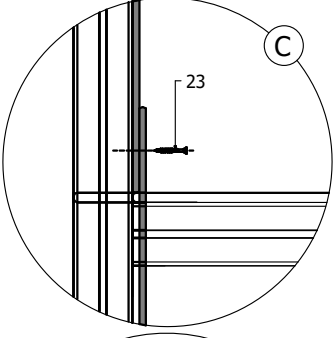
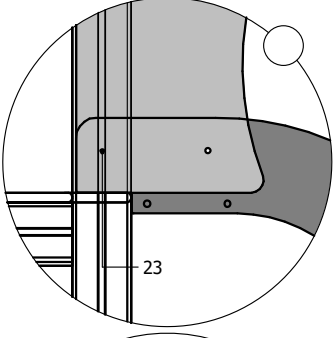
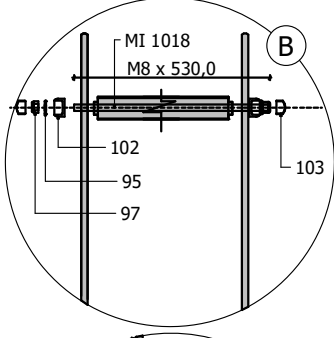
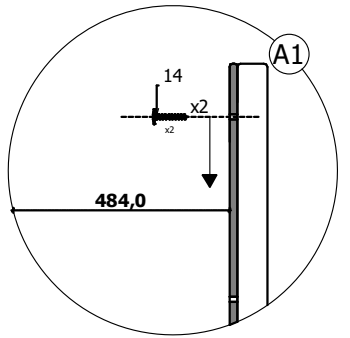
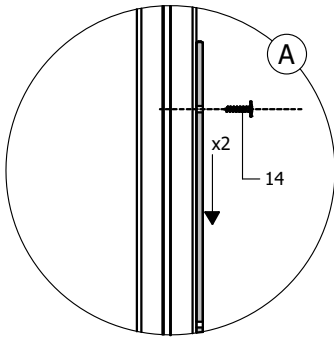
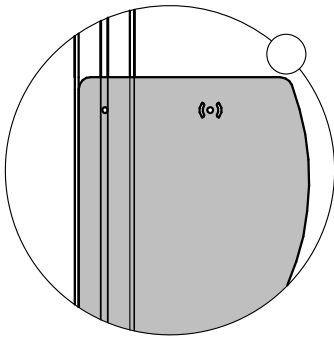
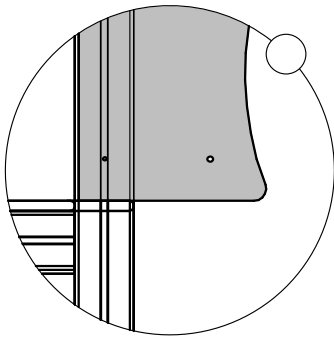

1

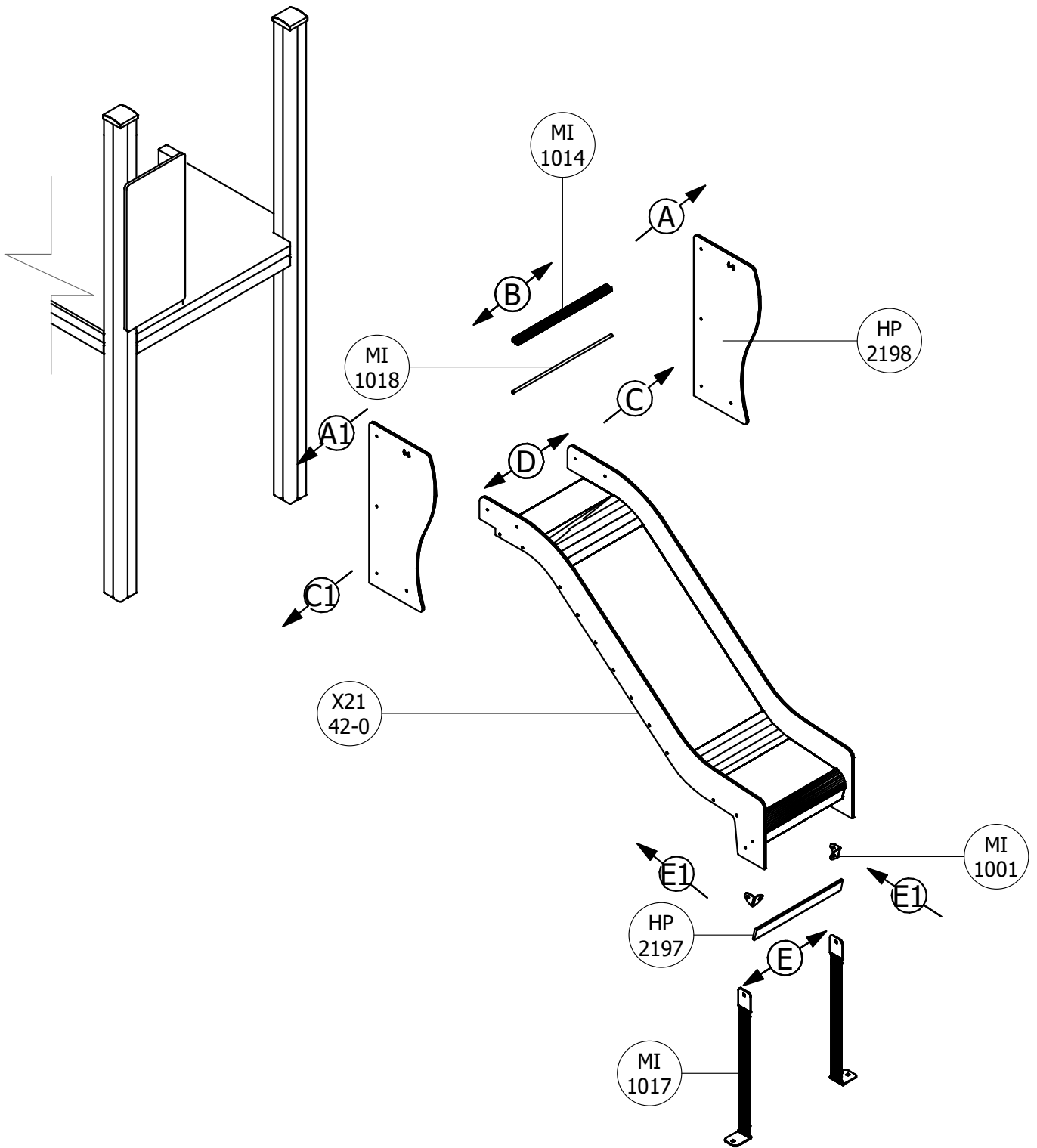

The slide should be positioned so, that the slope does not face south to reduce absorbed heat from the sun!

*Slidkalniņš jānovieto tā, lai slīdvirsma nebūtu tiešā saules ietekmē!*

Vältā asentamasta liukua suoraan auringon paisteeseen kuumuuden välttämiseksi.

**KE** 120

**ASSEMBLY INSTRUCTION**

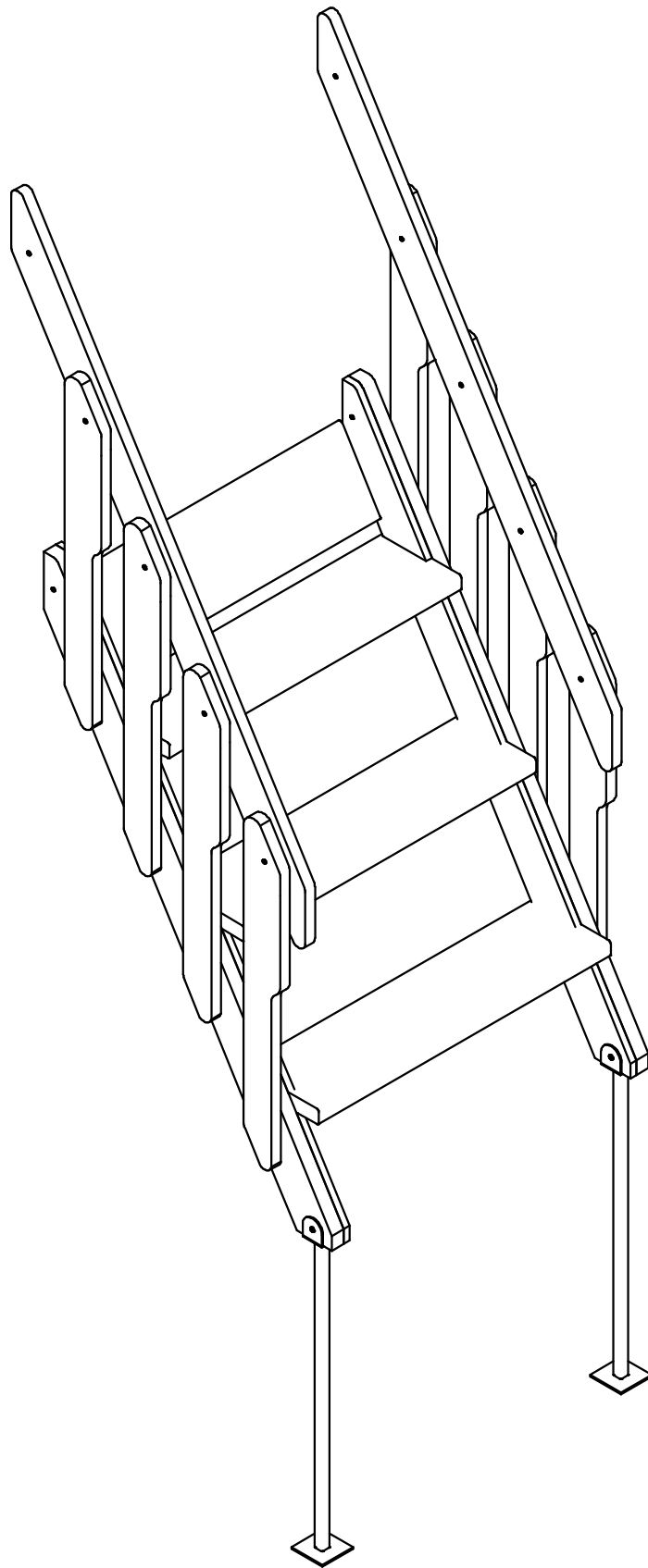





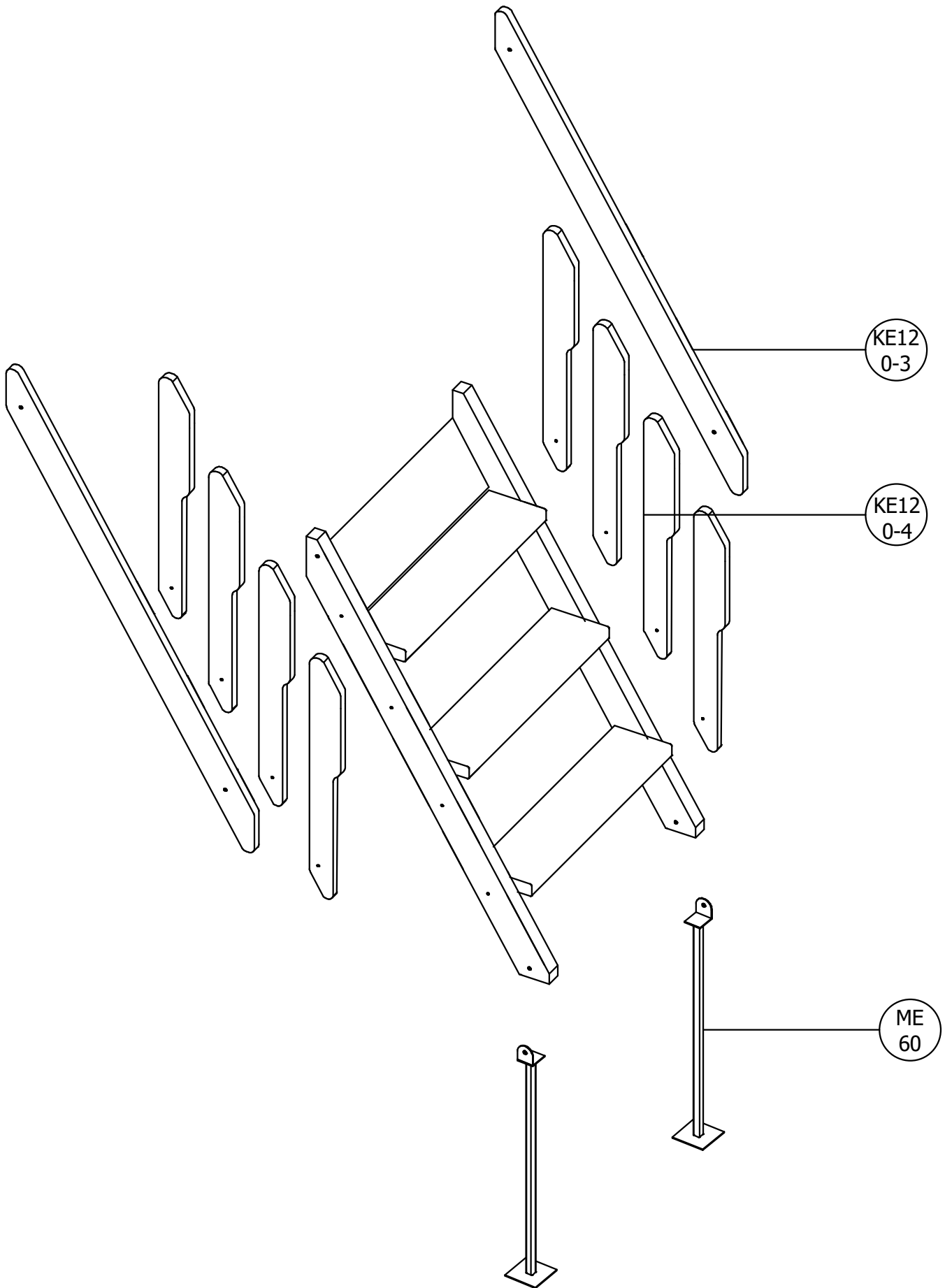

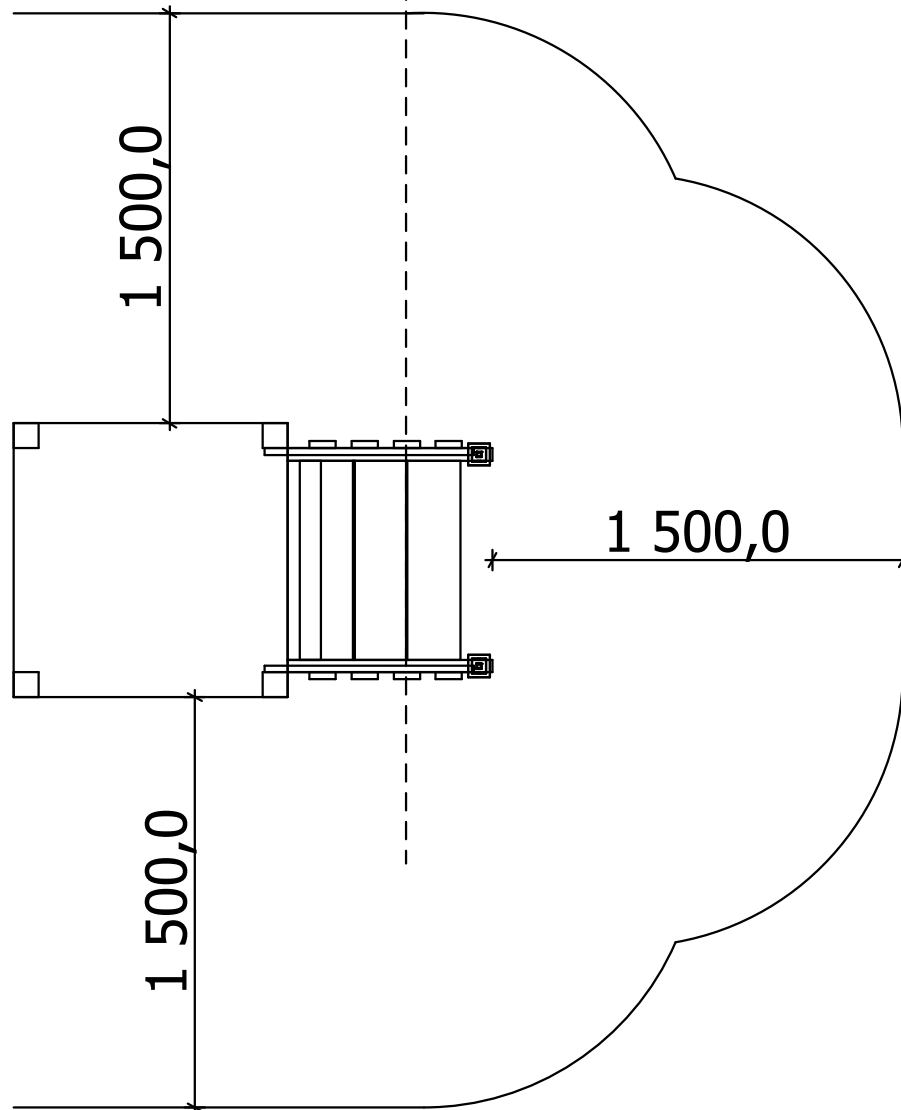
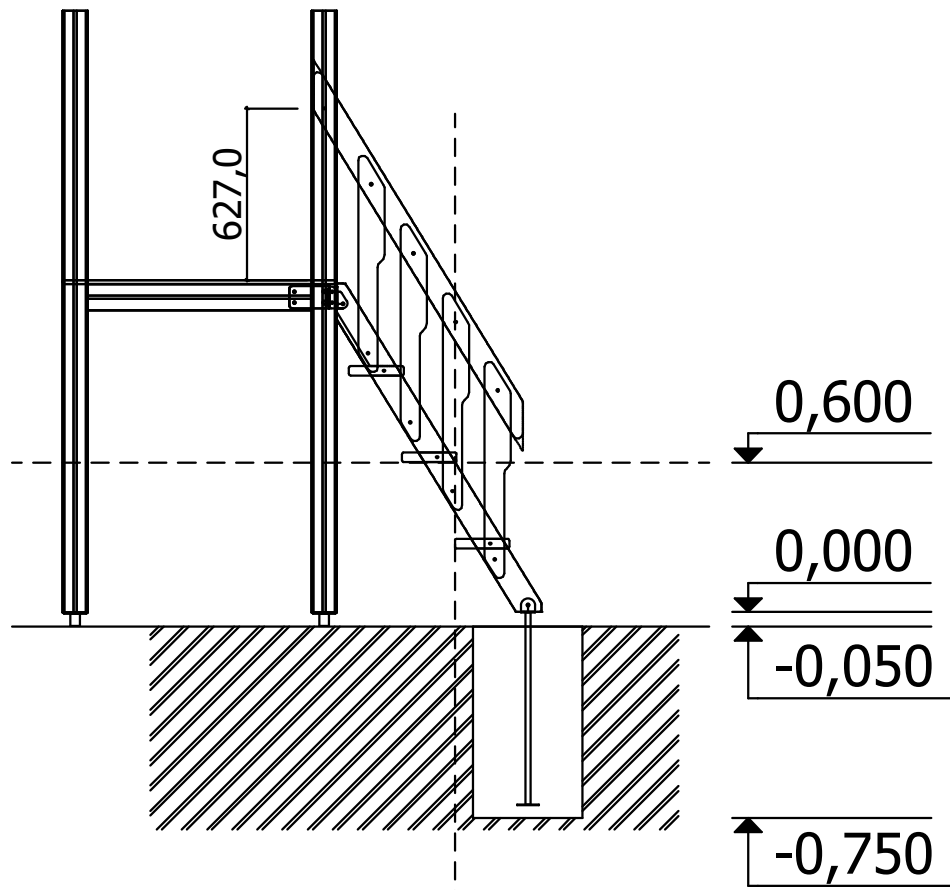

**KPLN DESIGN**

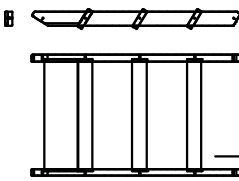
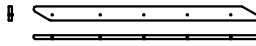
Equipment overview / *Iekārtas kopskats* /

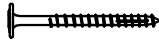
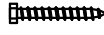

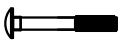

Specification / *Specifikācija*

<p>KE120-0</p>  <p>1</p>	<p>KE120-3</p>  <p>2</p>	<p>KE120-4</p>  <p>8</p>	<p>ME60</p>  <p>2</p>
<p>11</p> <p>8 x 80</p>  <p>2</p>	<p>42</p> <p>8 x 60</p>  <p>8</p>	<p>65</p> <p>8 x 60</p>  <p>10</p>	<p>ME39</p>  <p>2</p>
<p>66</p> <p>8 x 65</p>  <p>2</p>	<p>92</p> <p>M8</p>  <p>20</p>	<p>97</p> <p>M8</p>  <p>12</p>	
<p>100</p>  <p>20</p>	<p>101</p>  <p>20</p>		

Detail steps / *Montāžas soļi*

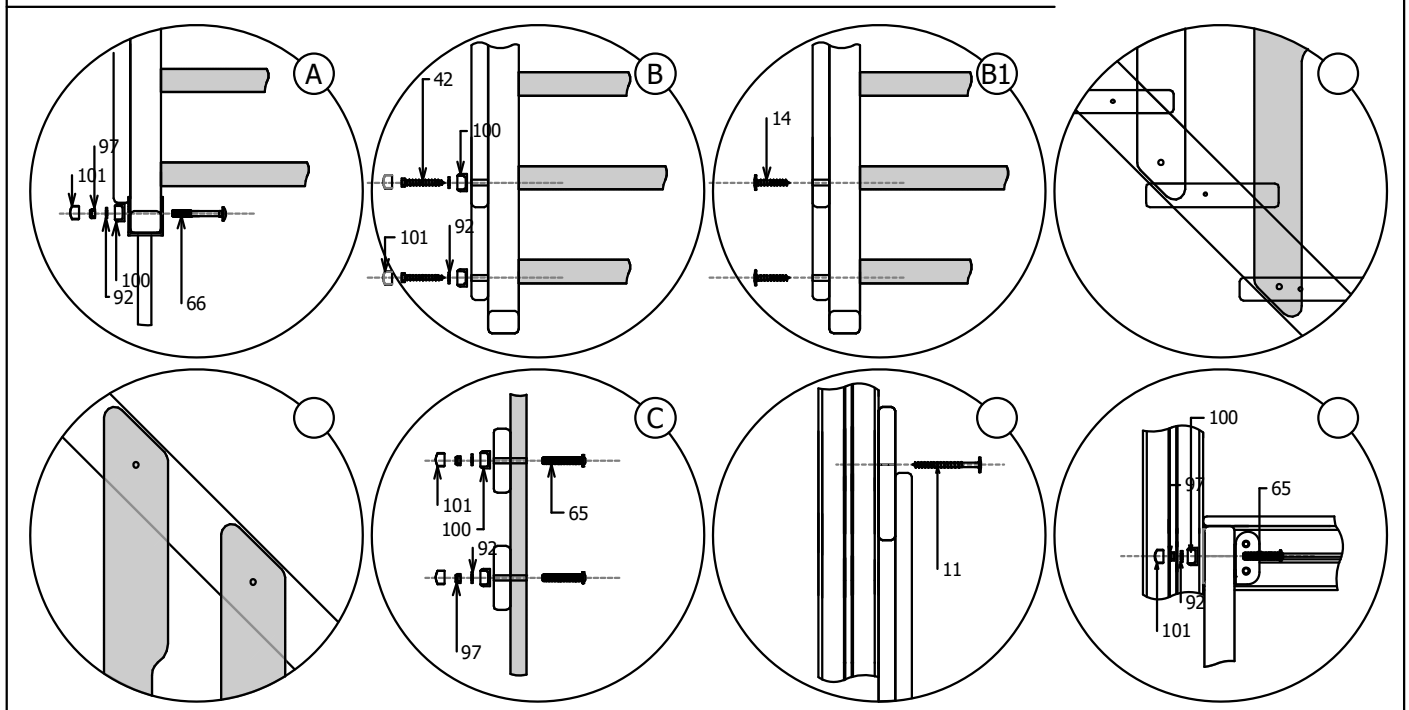

1

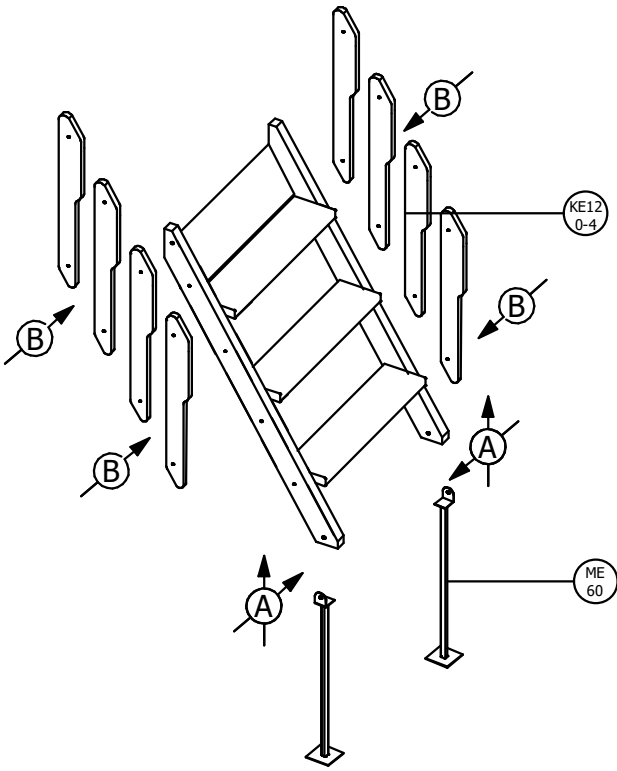

2

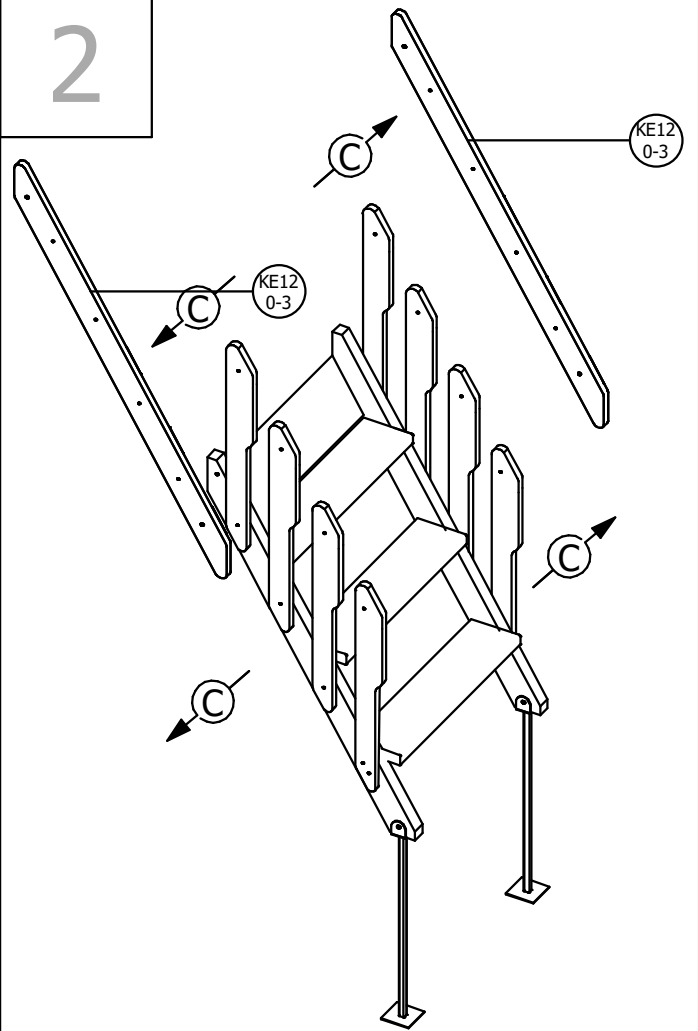

3

