

NG2009-E

ASSEMBLY INSTRUCTION

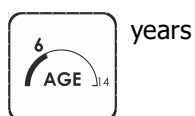
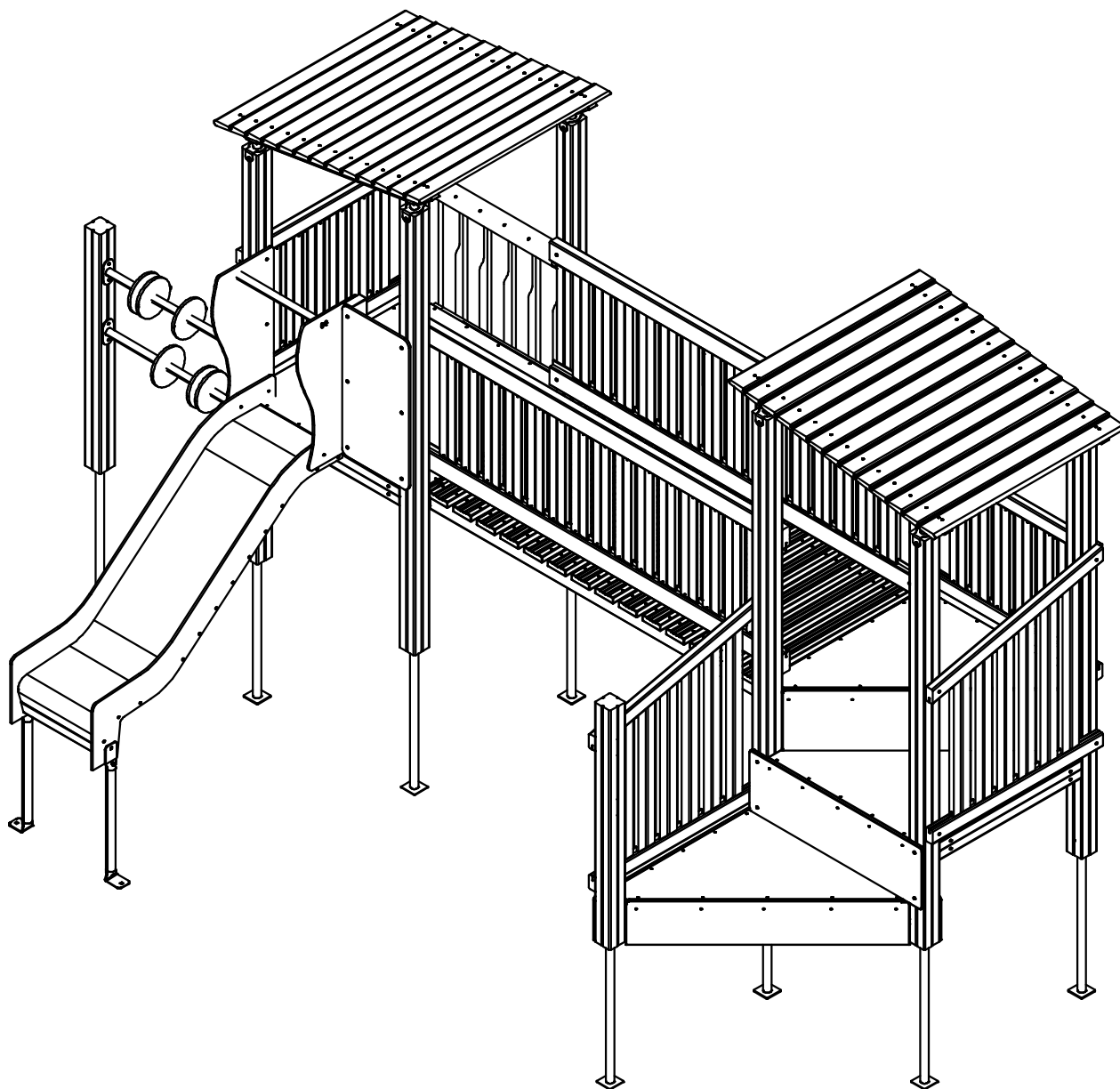

< 6

years



< 8

users

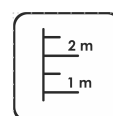

0,81 m

FHF



Jūrmalas Mežaparki Ltd.

1 Garkalnes street,
Jūrmala, LV-2011, Latvia

bērnu rotaļu laukumi info@jmp.lv, www.jmp.lv, +371 67732317

EN 9100
BUREAU VERITAS
Certification





Instalation provisions / *Montāžas noteikumi*

Before equipment installing, read the information about the location of the play equipment, the requirements of the safety zone, the depth of the concrete, the choice of shock-absorbing surfaces, and the installation time.

Take into account the requirement of the safety zone (it must be at least 1,50 m around equipment which is higher 0,60 m, 2,50 m around equipment if the equipment is higher than 1,50 m), which are shown in the assembly instruction, see "Overview". Dangerous or traumatic objects, such as concrete supports, wooden stumps, and stones and other objects not related to playing /exercise are forbidden in this installation area. The equipment cannot be installed on a hard surface - concrete, asphalt surface, as well as on a slope if the angle of fall is bigger than 2°. It is not recommended to install equipment with too loose covering. When choosing the location of the equipment, pay attention to the direction of the sun, the sliding surface must not be in direct sunlight. Equipment must be leveled regardless of technical or natural considerations. The installation of the equipment and its elements is carried out in accordance with the assembly instructions. Detailed assembly steps are listed on the "Assembly steps" page. Each element has its own assembly instructions. Please follow the dimensions carefully.

Preparation of foundations are according to the requirements of the assembly instructions, see "Concreting - Digging". Make sure the foundation is stable. The thickness of the safety cover must be in accordance with the instructions given, see "Potential surface". The use of the device is allowed after 2 days when the concrete has completely hardened. The structures of the equipment are fastened with screwed metal foundations, using concrete casting at the installation site.

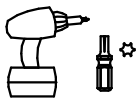
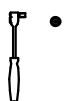
Check the equipment carefully by using the checklist. The area required for construction may increase in equipment installation time. Children are not allowed to participate in the installation work, as well as the use of the equipment is prohibited until it is fully installed, inspected and the safety zones are free of obstacles. The soil must be tramp after digging and installation work. Equipment safety and function tests are performed when the equipment is fully installed and earthworks are completed. Installation instructions are stored and documented in accordance with "Maintenance information".

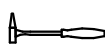
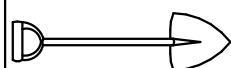
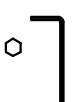
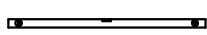
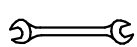
Potencial surfaces / *Segumi*

Surface coating under the play equipment should be applied according to the En 1176-1:2017 standard.

Segums zem rotaļu iekārtām jā'but saskaņā ar standartu LVS EN 1176-1:2018.

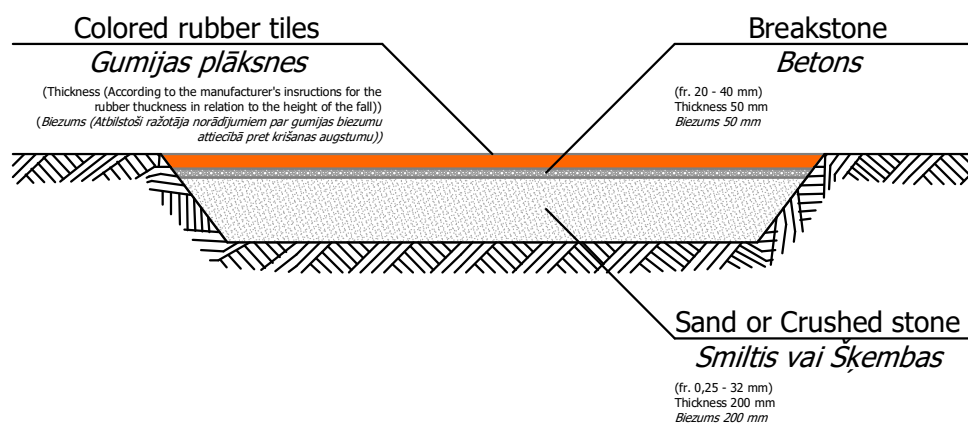
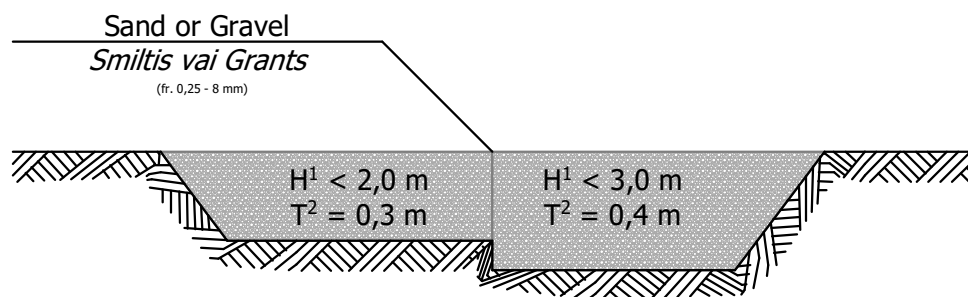
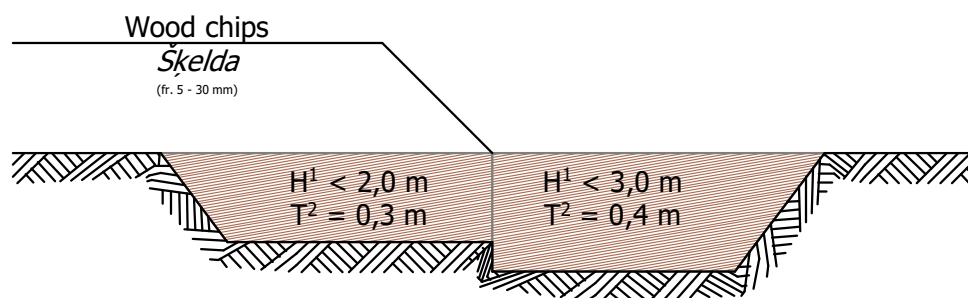
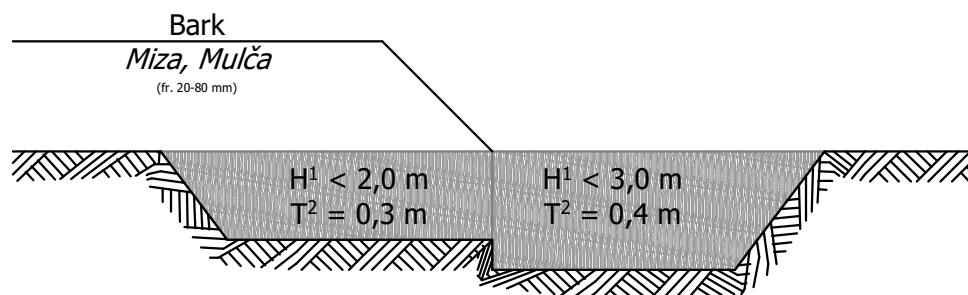
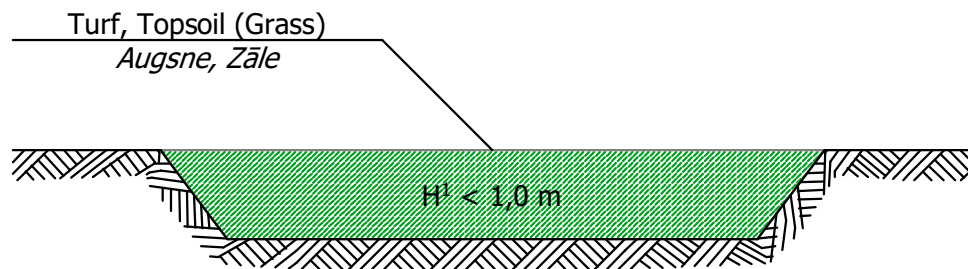

1 - Critical Height of Fall / *Krišanas augstums;*

2 - Loose Fill or Synthetic Surface Thickness / *Irdenā vai sintētiskā seguma biezums*

Equipment overview / Iekārtas kopskats / Yhteenveto

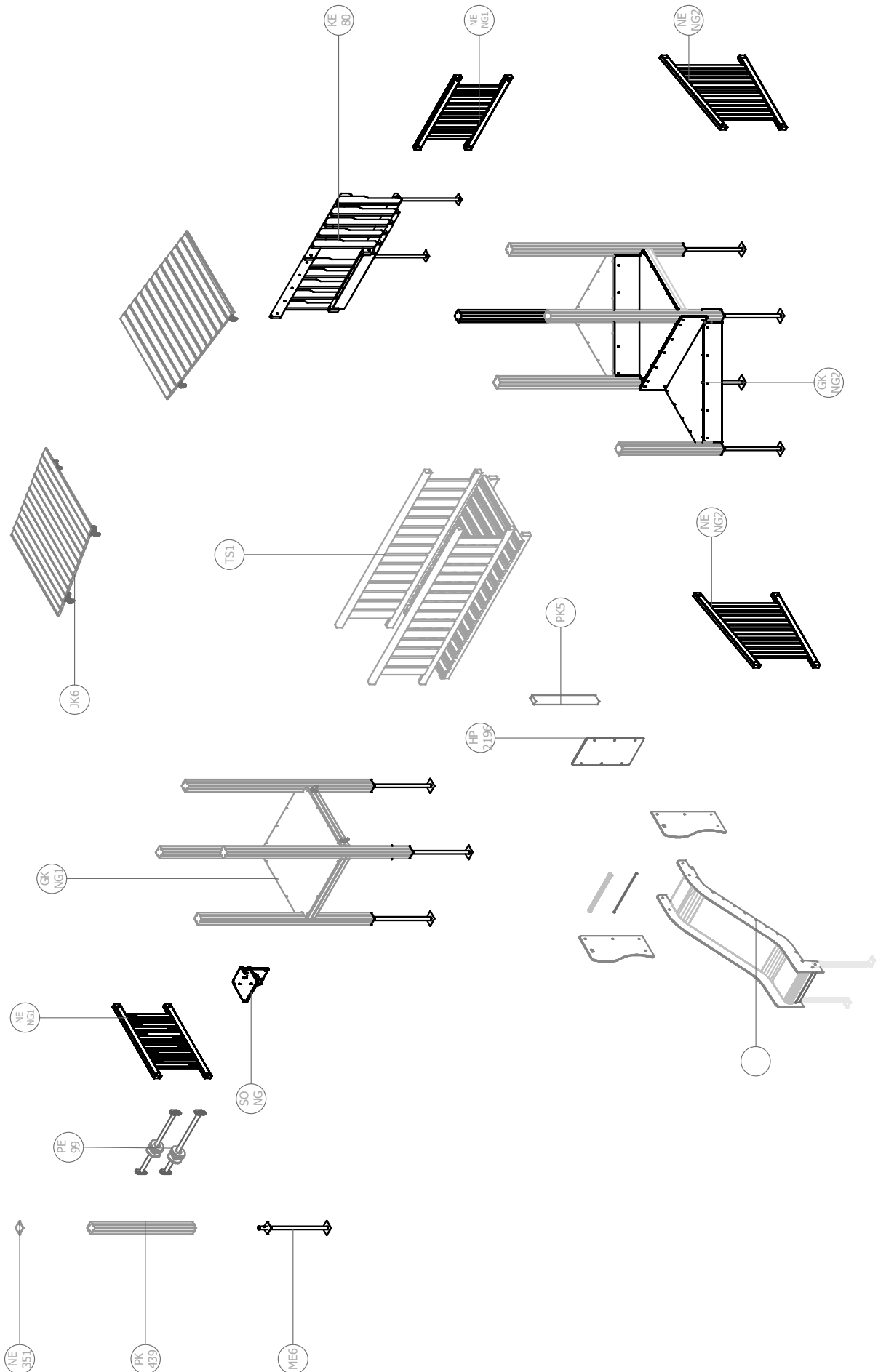

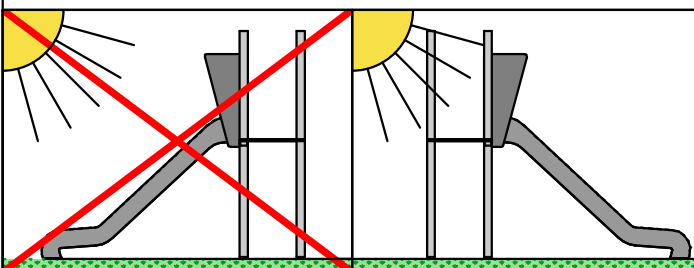
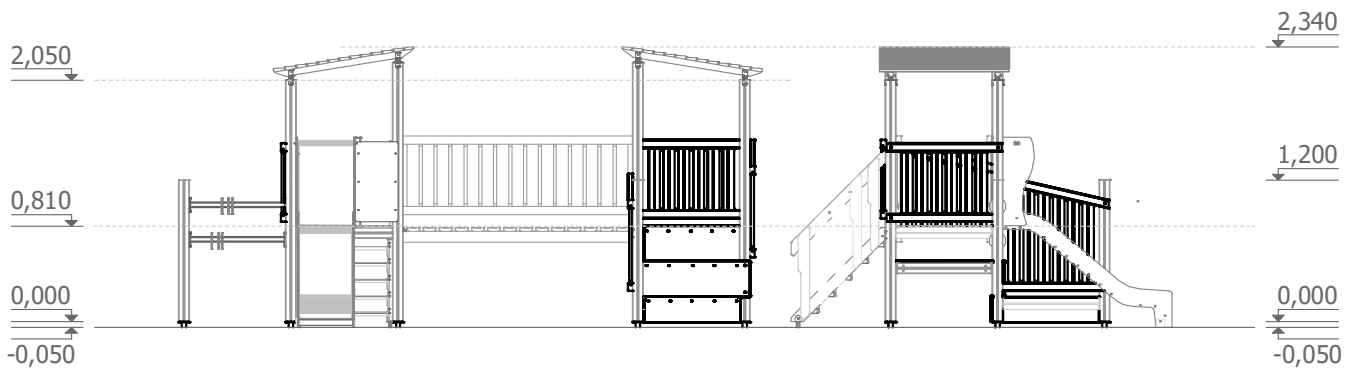
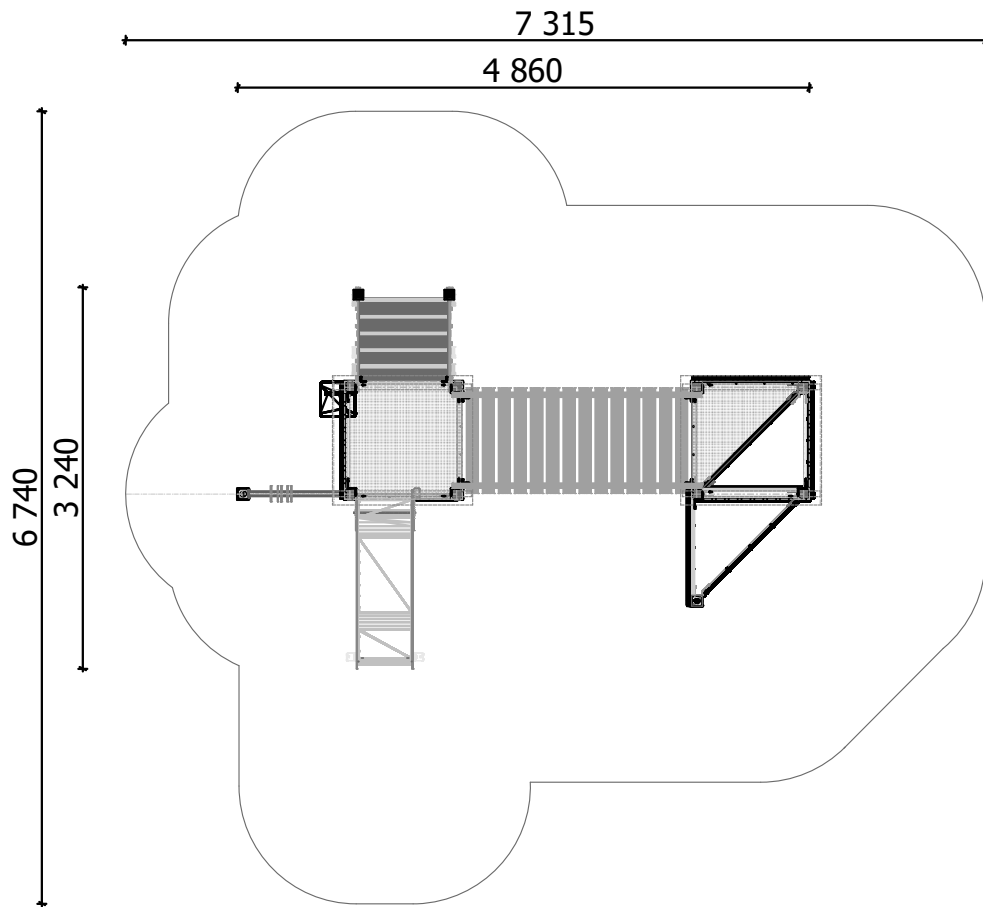

The slide should be positioned so, that the slope does not face south to reduce absorbed heat from the sun!

Slidkalniņš jānovieto tā, lai slīdvirsma nebūtu tiešā saules ietekmē!

Vältā asentamasta liukua suoraan auringon paisteeseen kuumuuden välttämiseksi.

Concreting - Digging / *Betoněšana - Rakšana / Perustus*

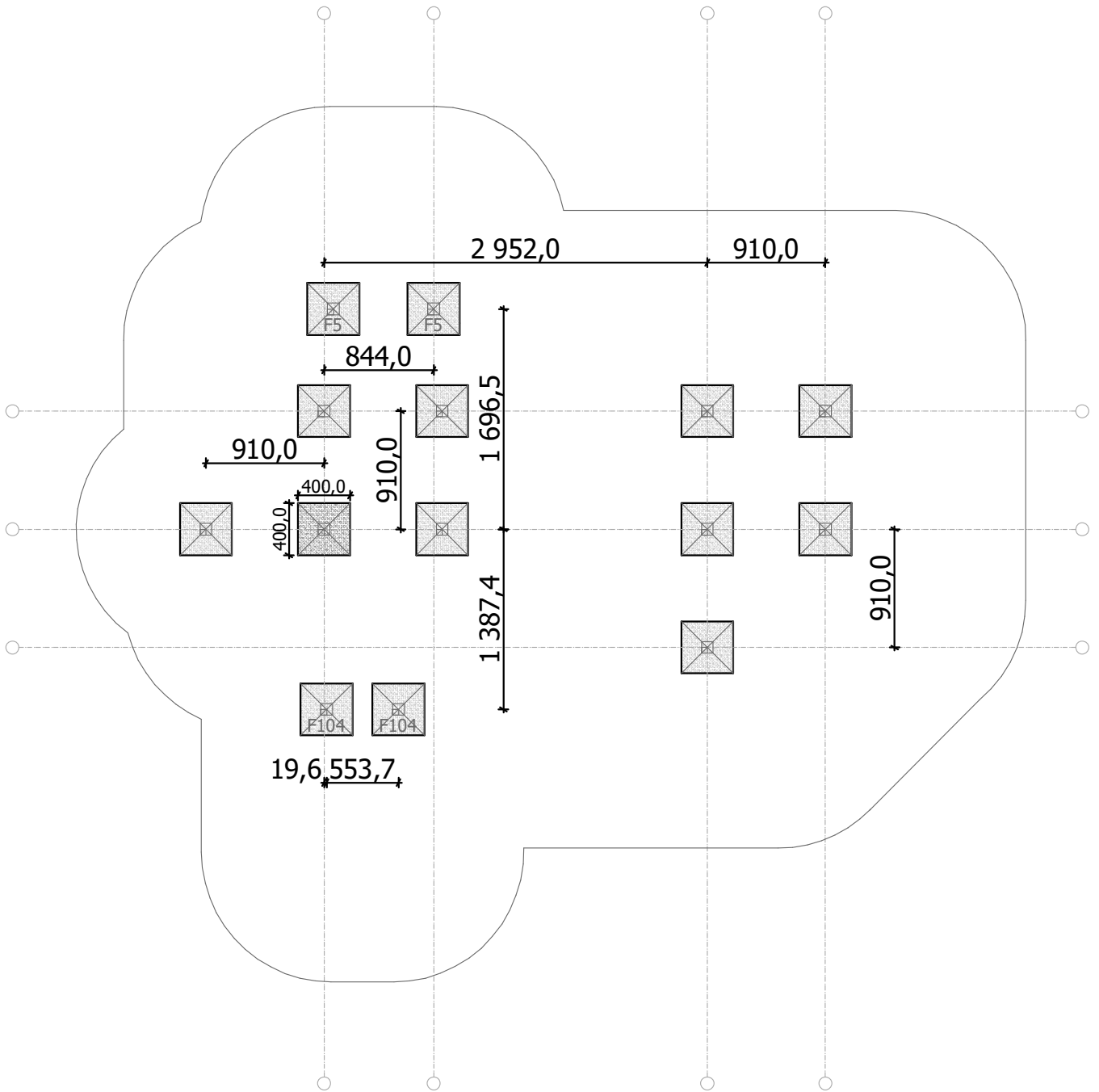

F1

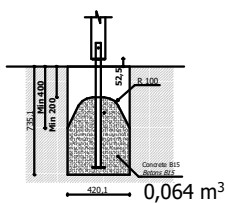



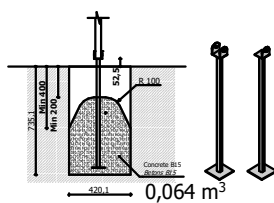



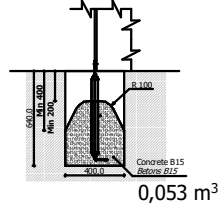

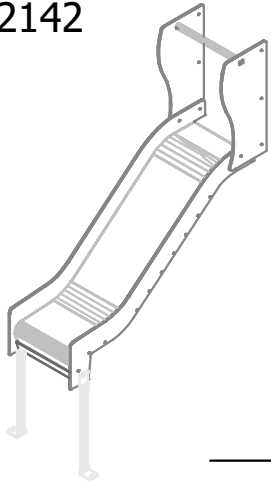
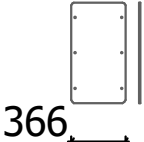
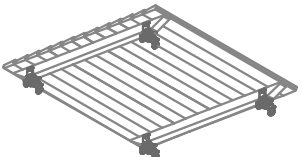
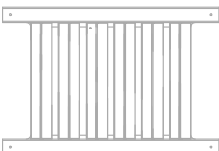
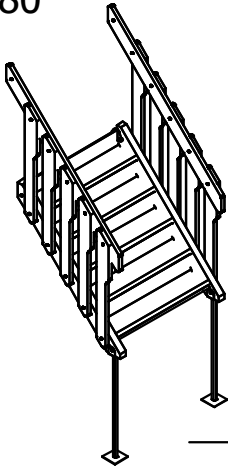
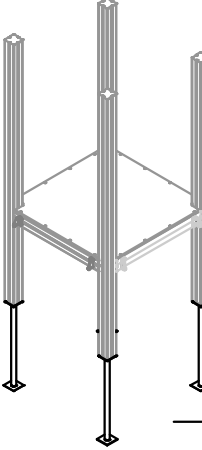
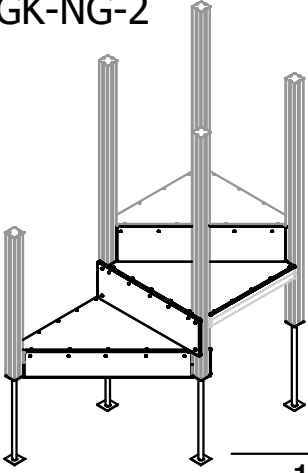
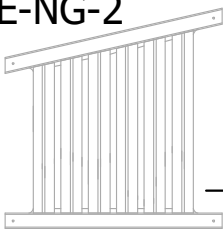
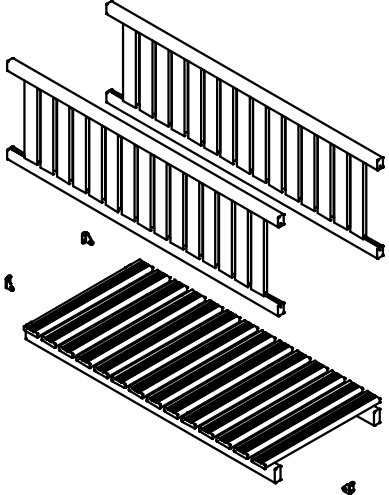

F5

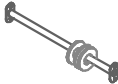
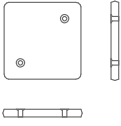

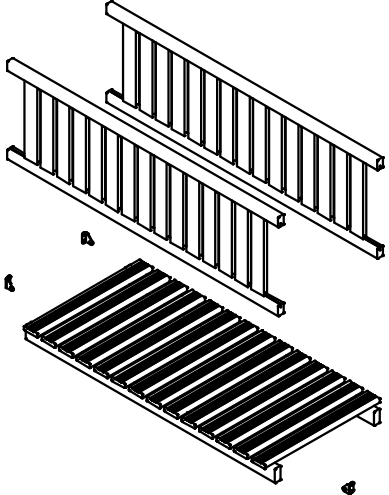







F104

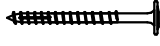
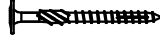

Specification / *Specifikācija* / *Osaluettelo*

<p>X2142</p>  <p>1</p>	<p>HP2196</p>  <p>366</p> <p>1</p>	<p>JK6</p>  <p>2</p>	<p>NE-NG-1</p>  <p>2</p>
<p>KE80</p>  <p>1</p>	<p>GK-NG-1</p>  <p>1</p>	<p>GK-NG-2</p>  <p>1</p>	<p>NE-NG-2</p>  <p>2</p>
<p>TS1</p>  <p>1</p>	<p>PK5</p>  <p>750</p> <p>1</p>	<p>PE99</p>  <p>2</p>	
<p>NE351</p>  <p>1</p>	<p>PK439</p>  <p>1200</p> <p>1</p>	<p>TS1</p>  <p>1</p>	
<p>NE516</p>  <p>3</p>	<p>NE517</p>  <p>6</p>	<p>NE482</p>  <p>1</p>	<p>NE483</p>  <p>1</p>
<p>NE484</p>  <p>1</p>			

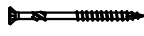
Specification / *Specifikācija* / Osaluettelo

<p>3</p>  <p>24</p>	<p>11</p>  <p>24</p>	<p>13</p>  <p>1</p>	<p>ME6</p>  <p>1</p>
<p>10</p>  <p>4</p>	<p>14</p>  <p>6</p>	<p>21</p>  <p>6</p>	<p>23</p>  <p>2</p>
<p>25</p>  <p>1</p>	<p>329</p>  <p>12</p>		

Detail steps / *Montāžas soli* / *Asennusvaiheet*

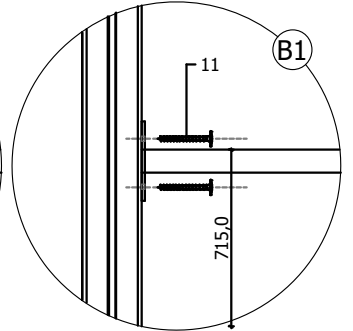
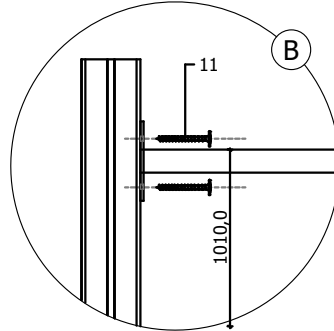
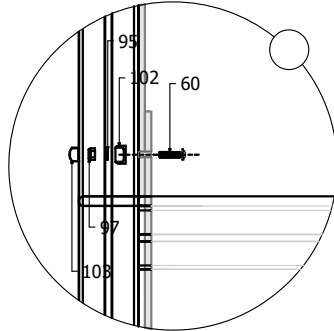
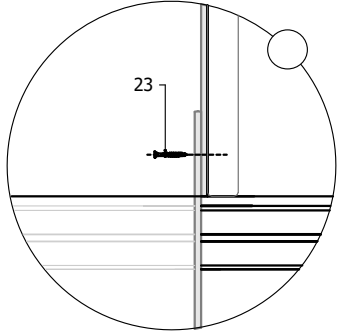
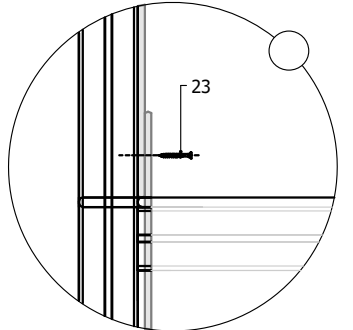
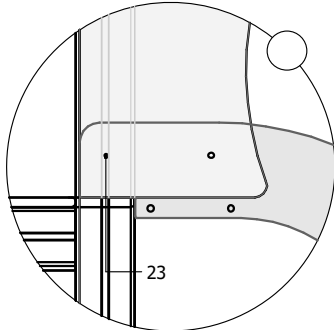
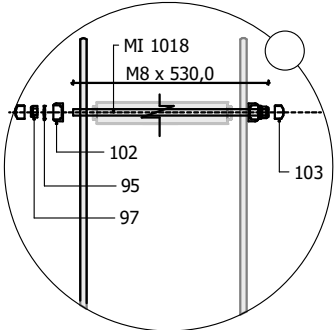
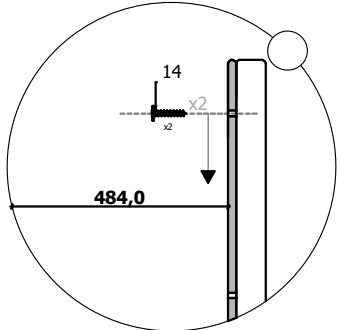
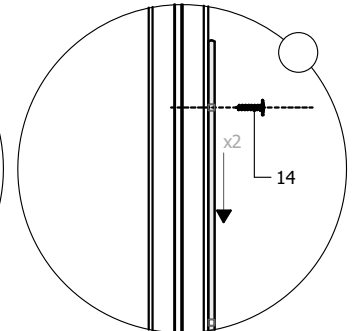
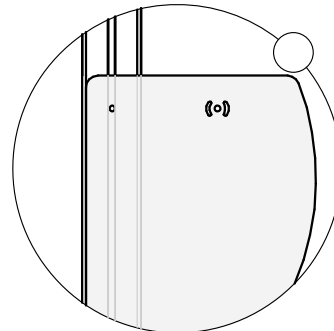
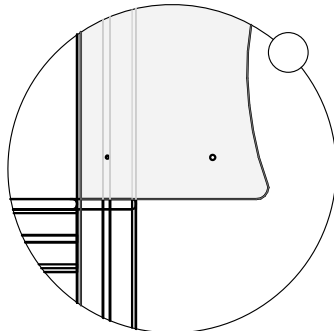
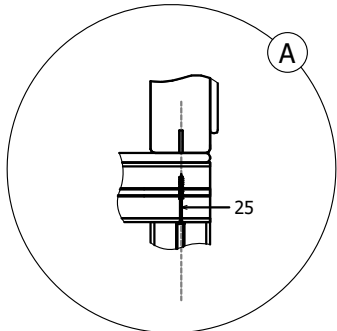
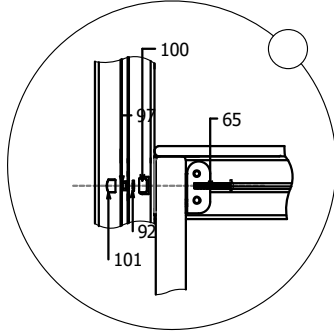
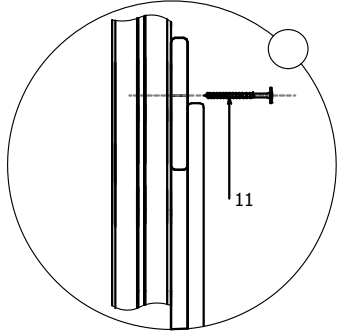
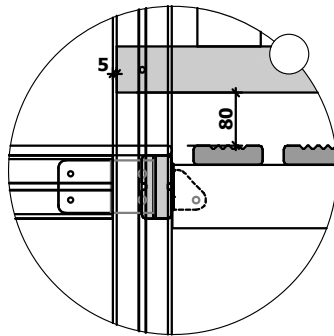
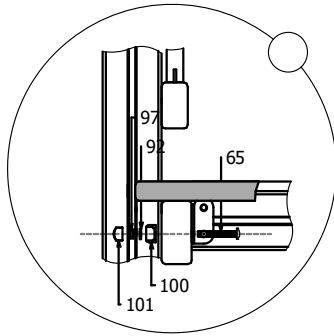
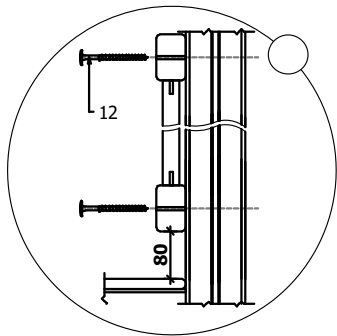

B

B1

Detail steps / *Montāžas soli* / *Asennusvaiheet*

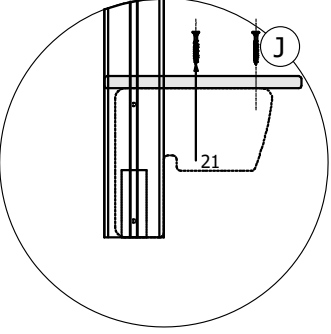
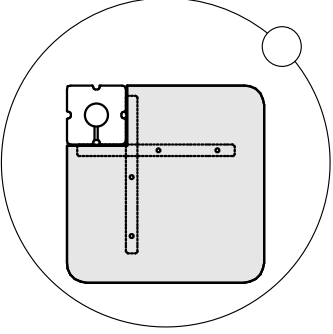
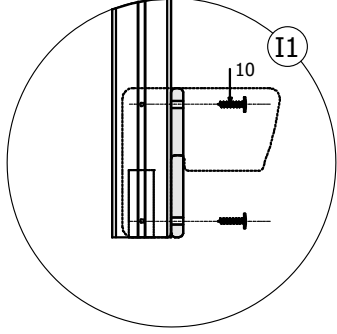
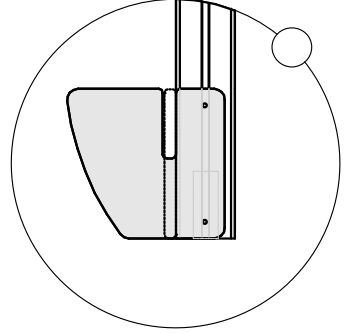
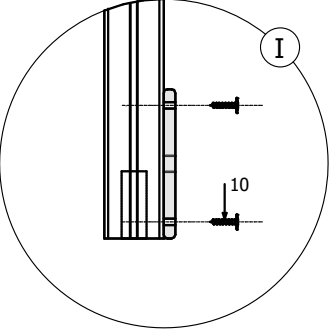
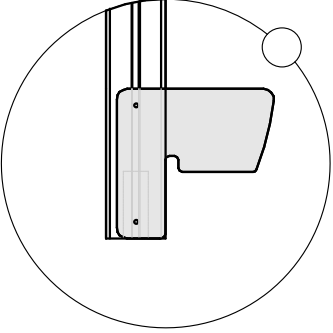
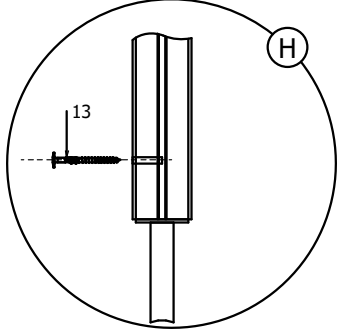
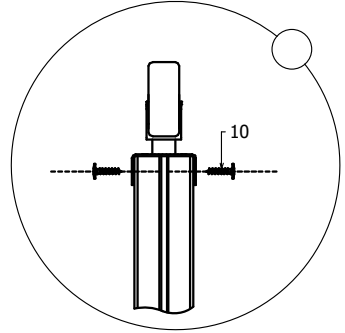
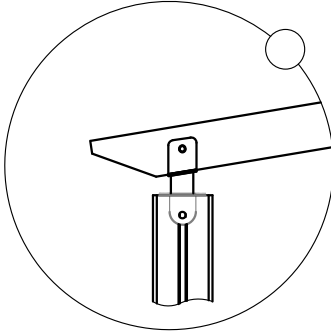
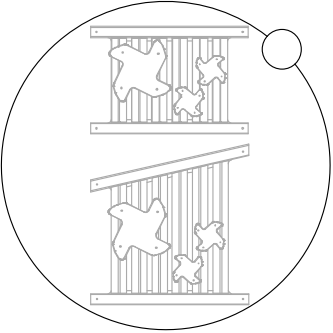
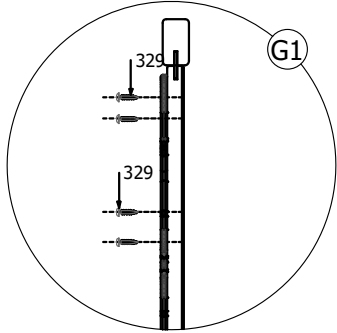
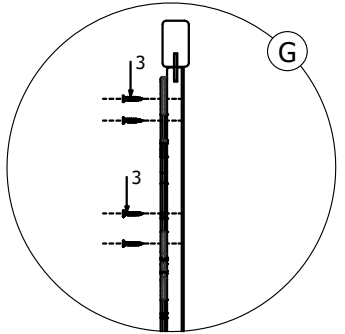
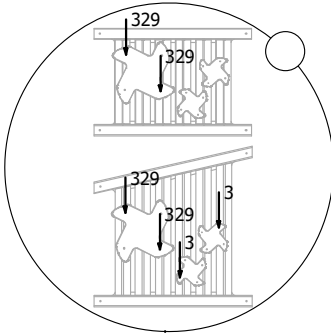
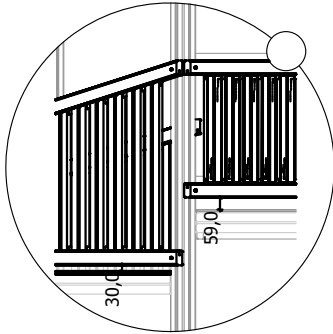
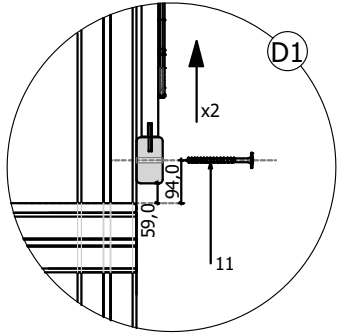
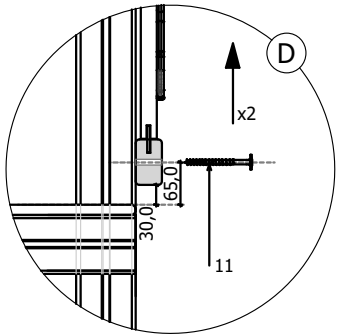
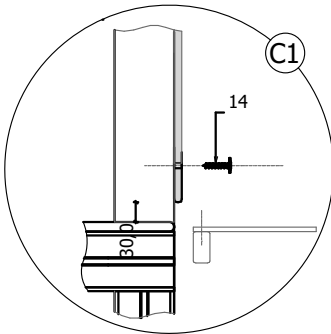
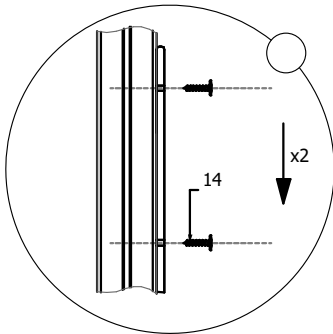
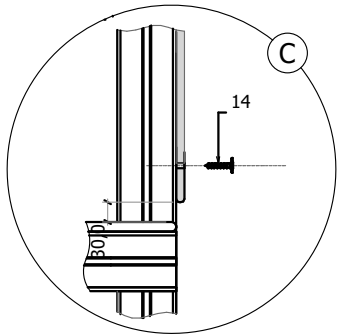

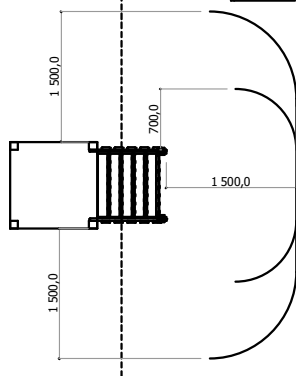
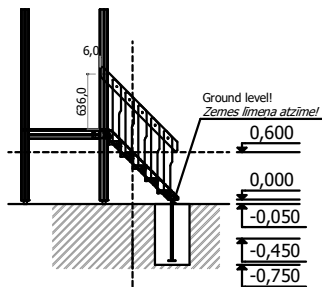
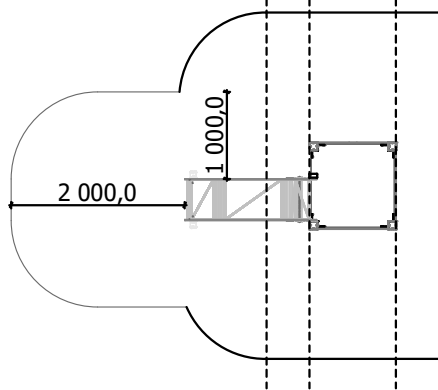
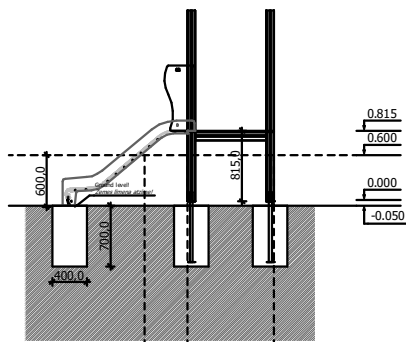
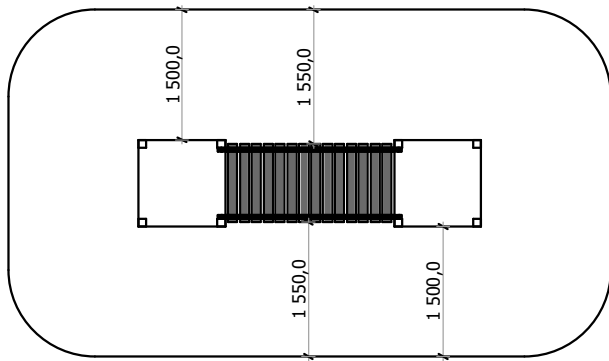
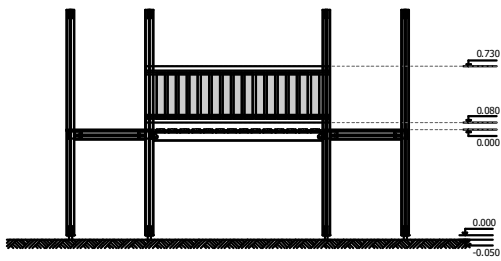

Decor adding places

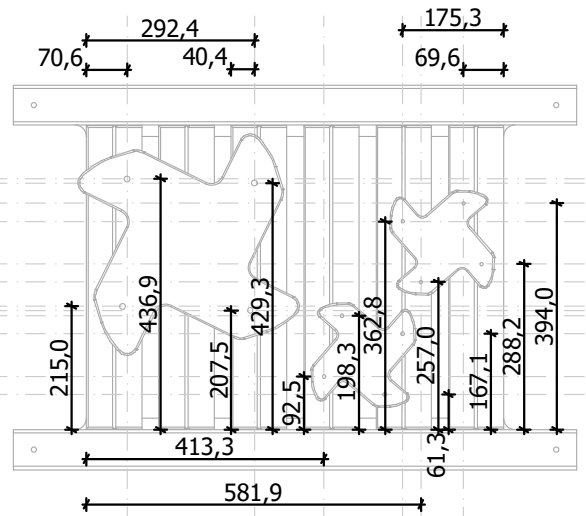

Must be used in the step "G"
Lietot "G" soli.

Decor adding places

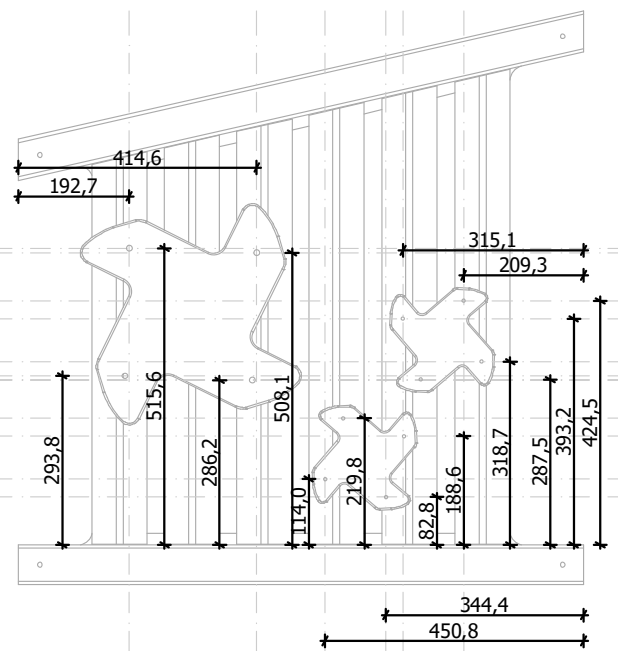

Must be used in the step "G"
Lietot "G" soli.

1

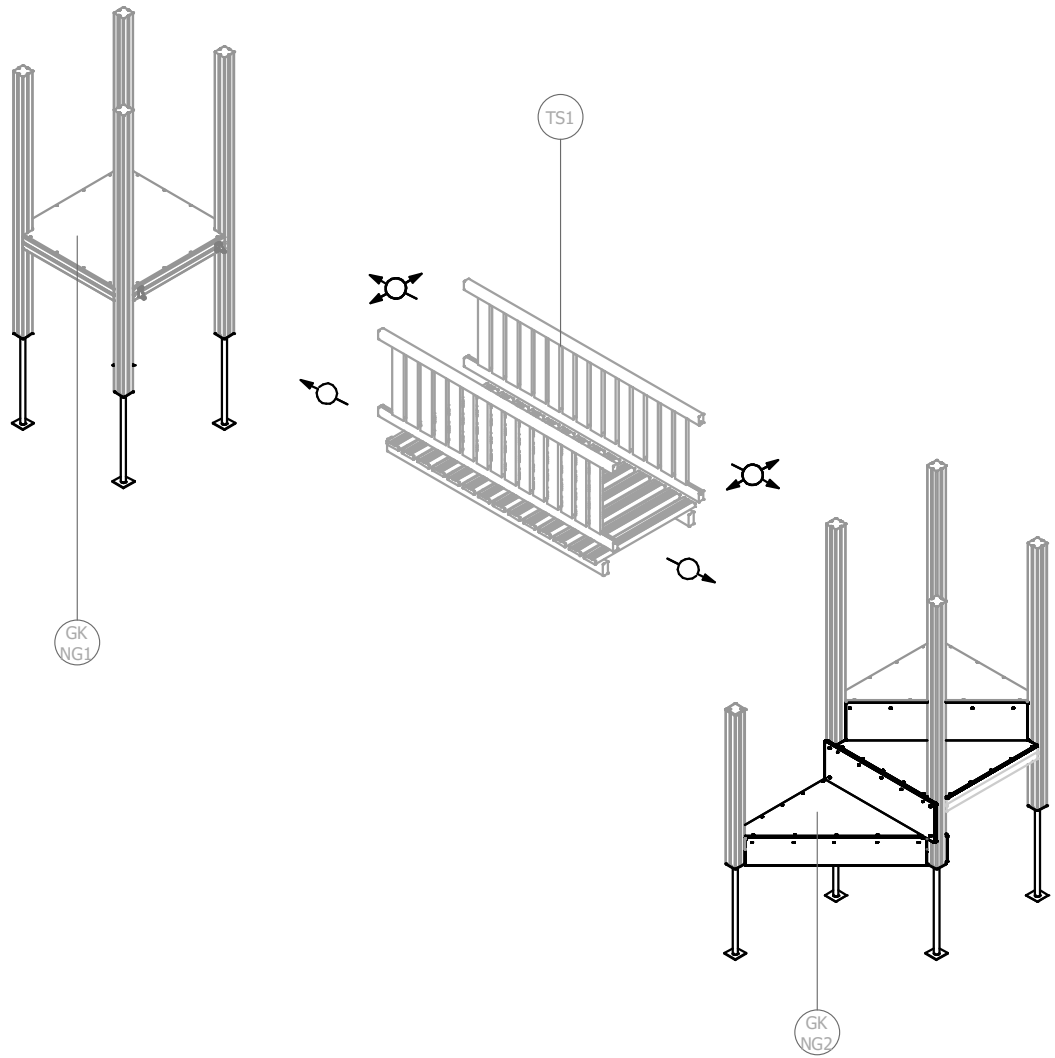

2

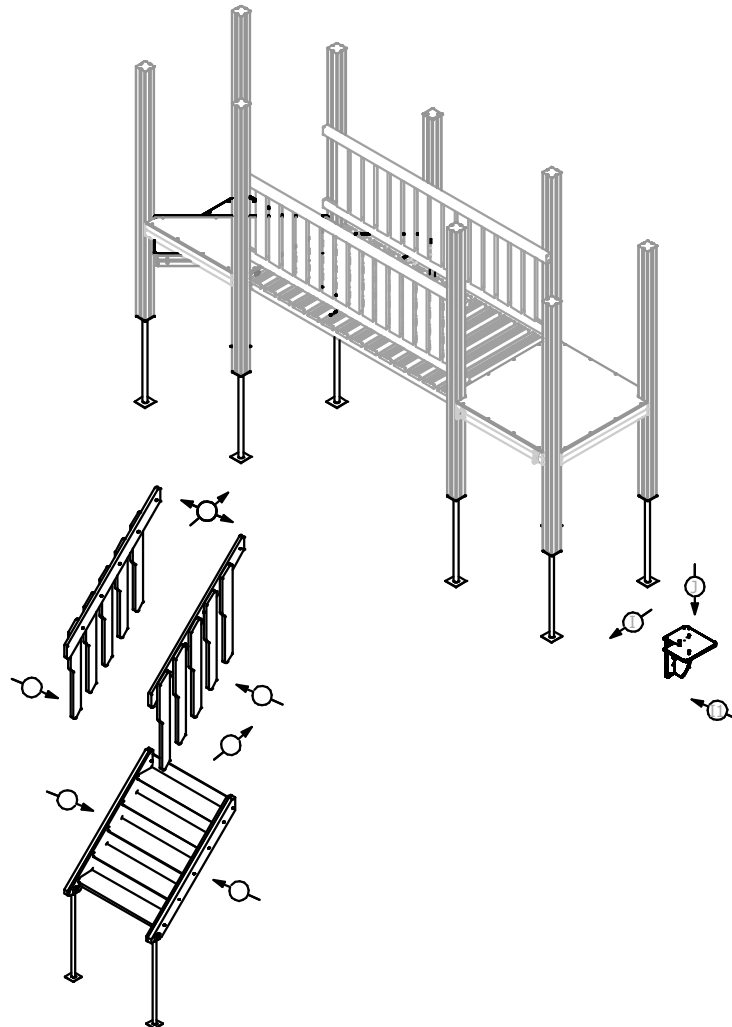

3

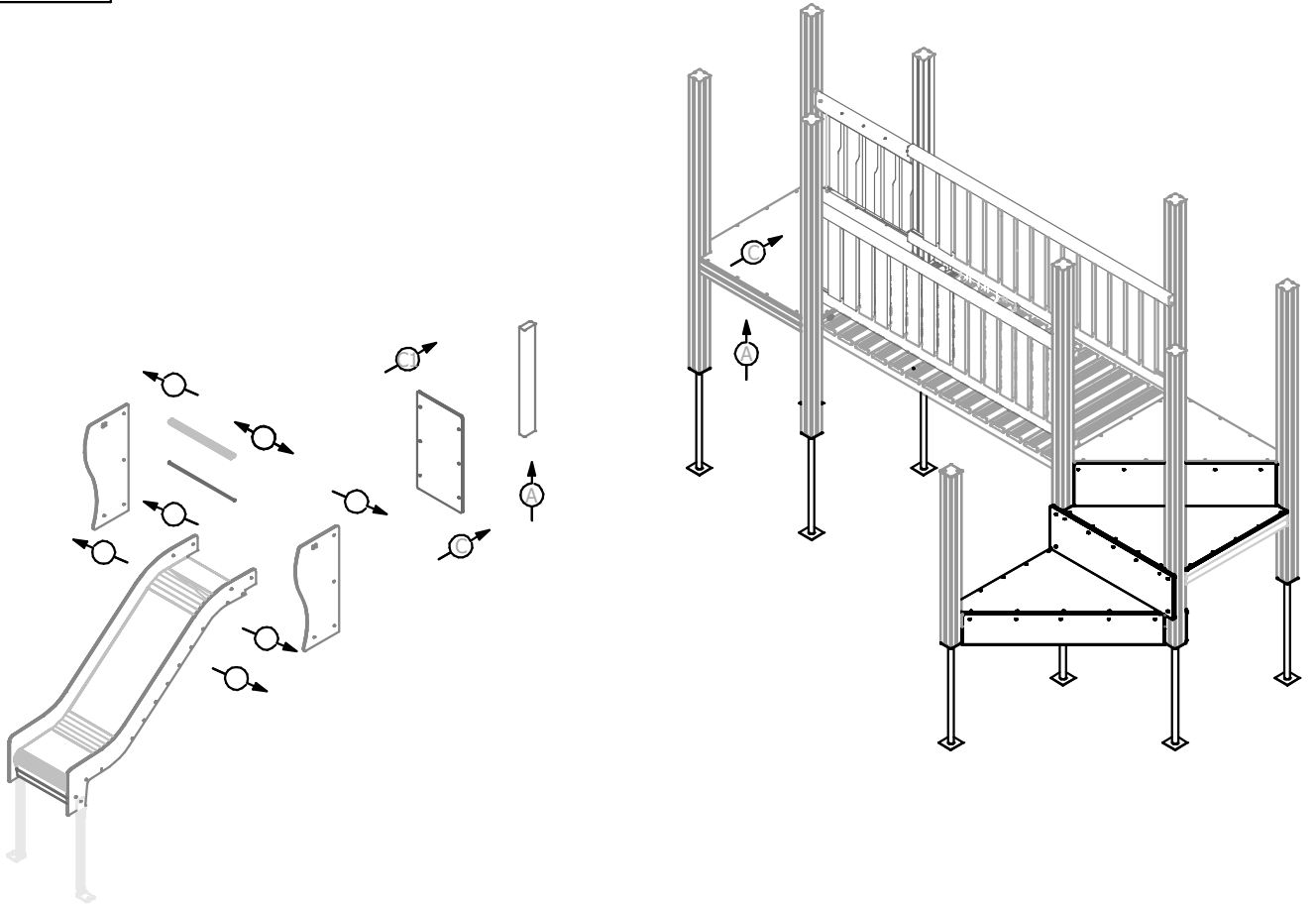

4

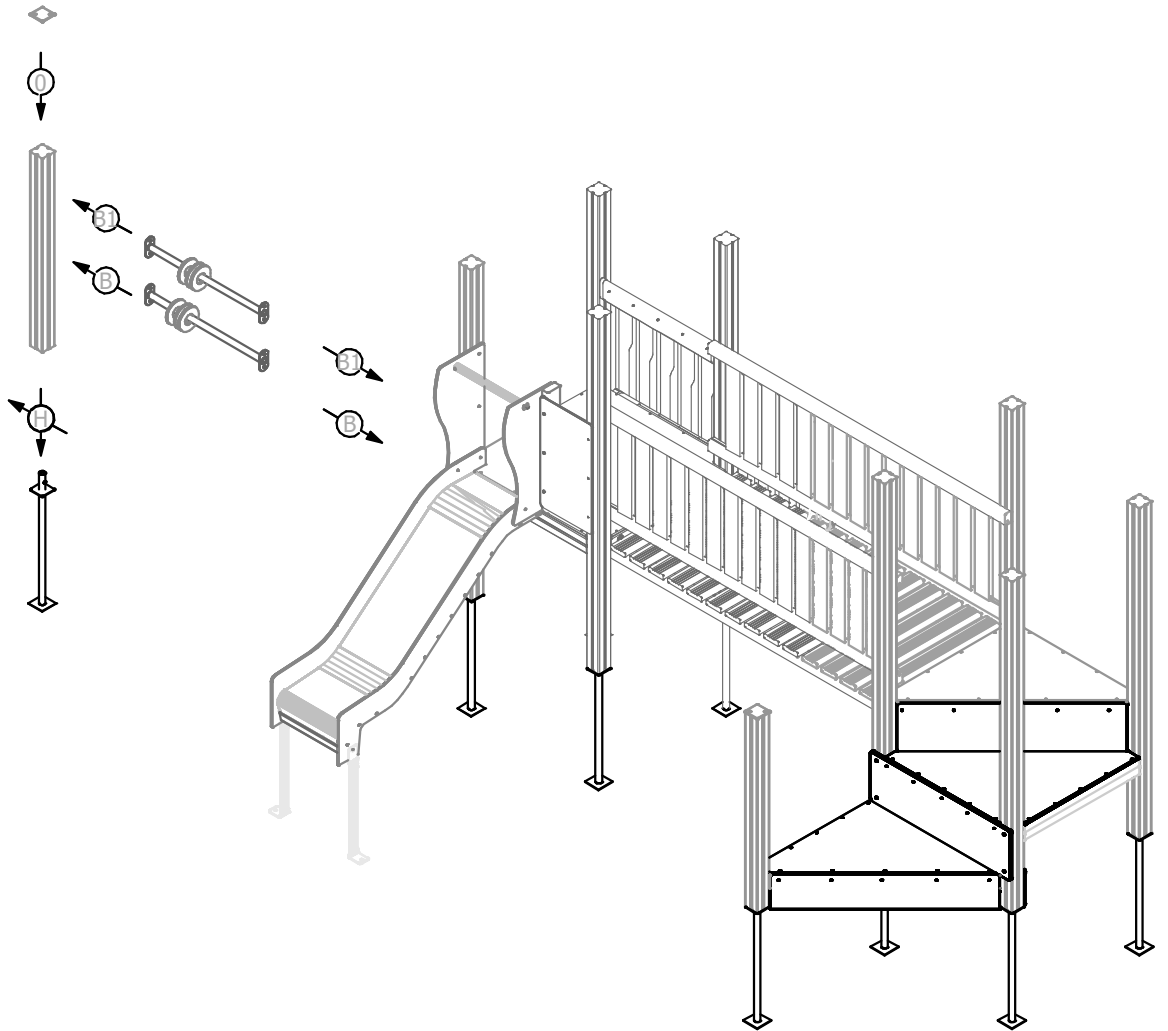

5

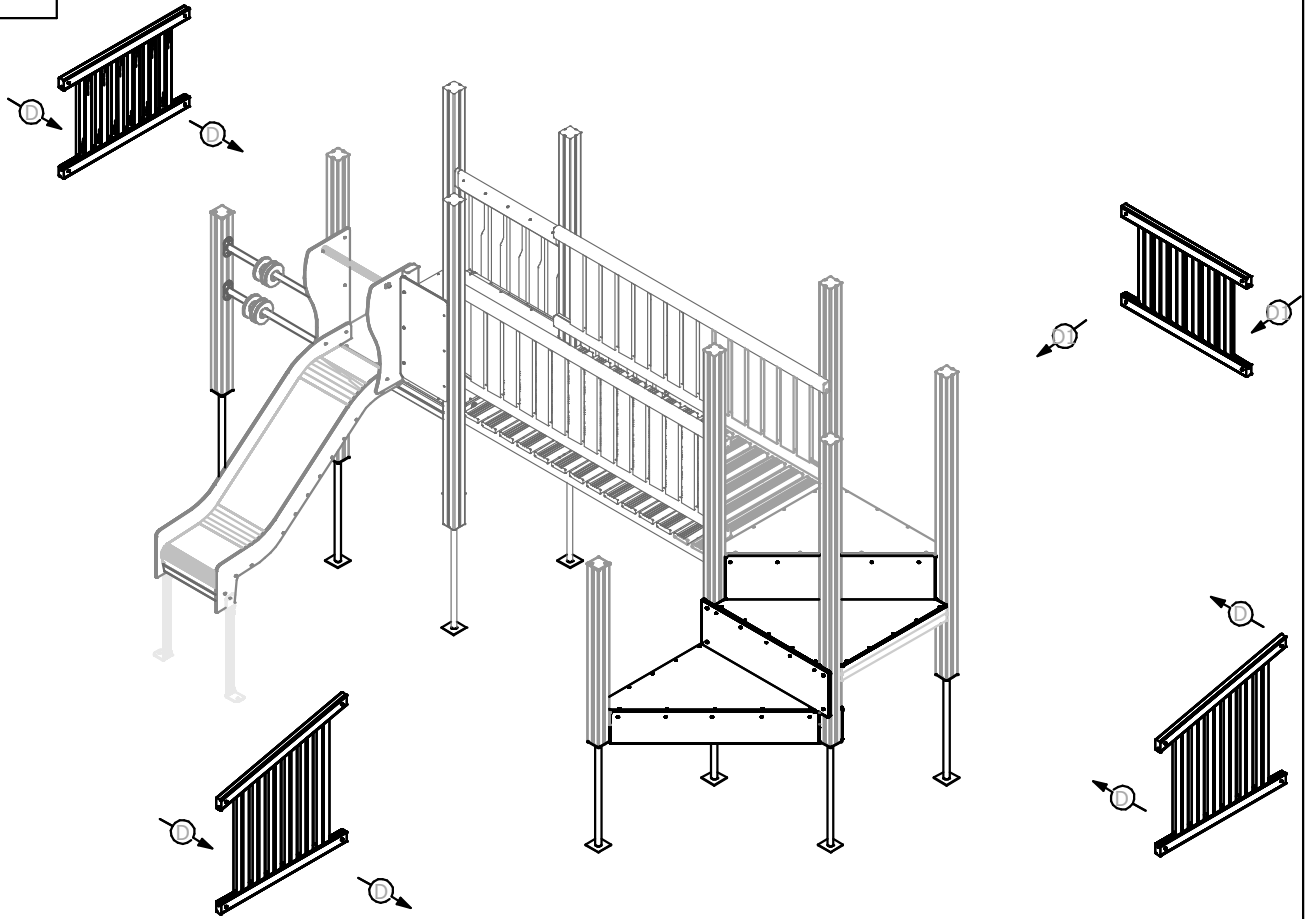

6

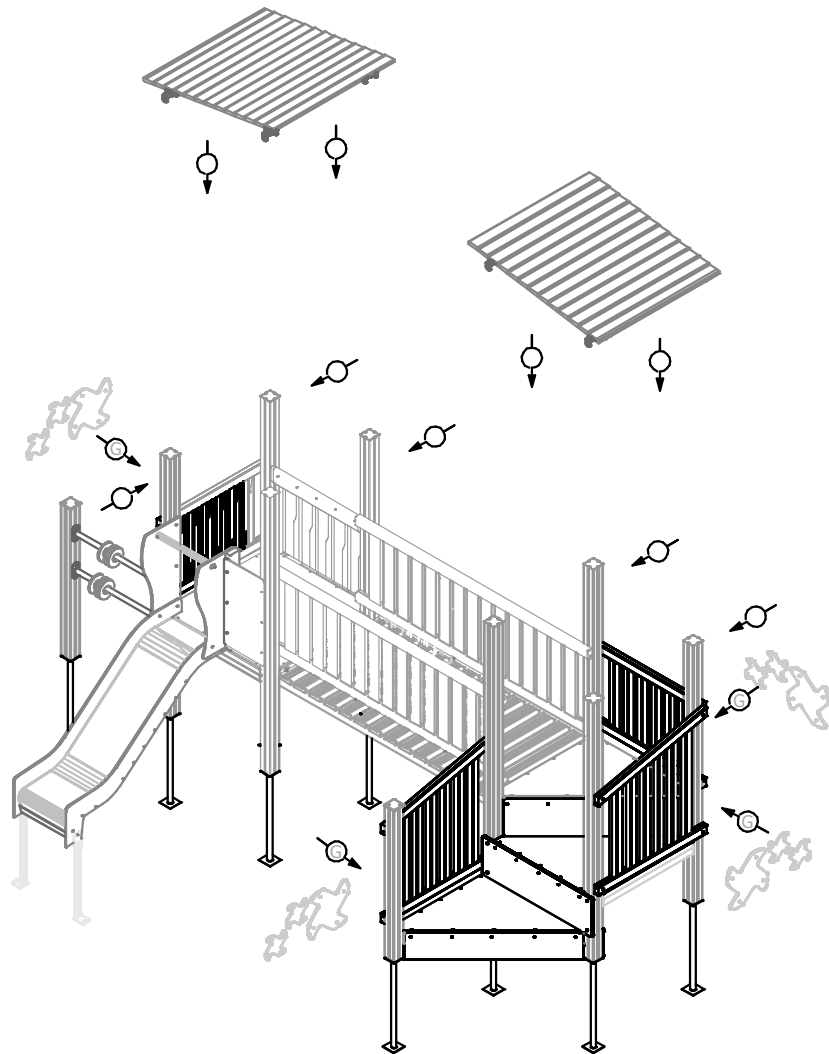

GK-NG-1-E

ASSEMBLY INSTRUCTION

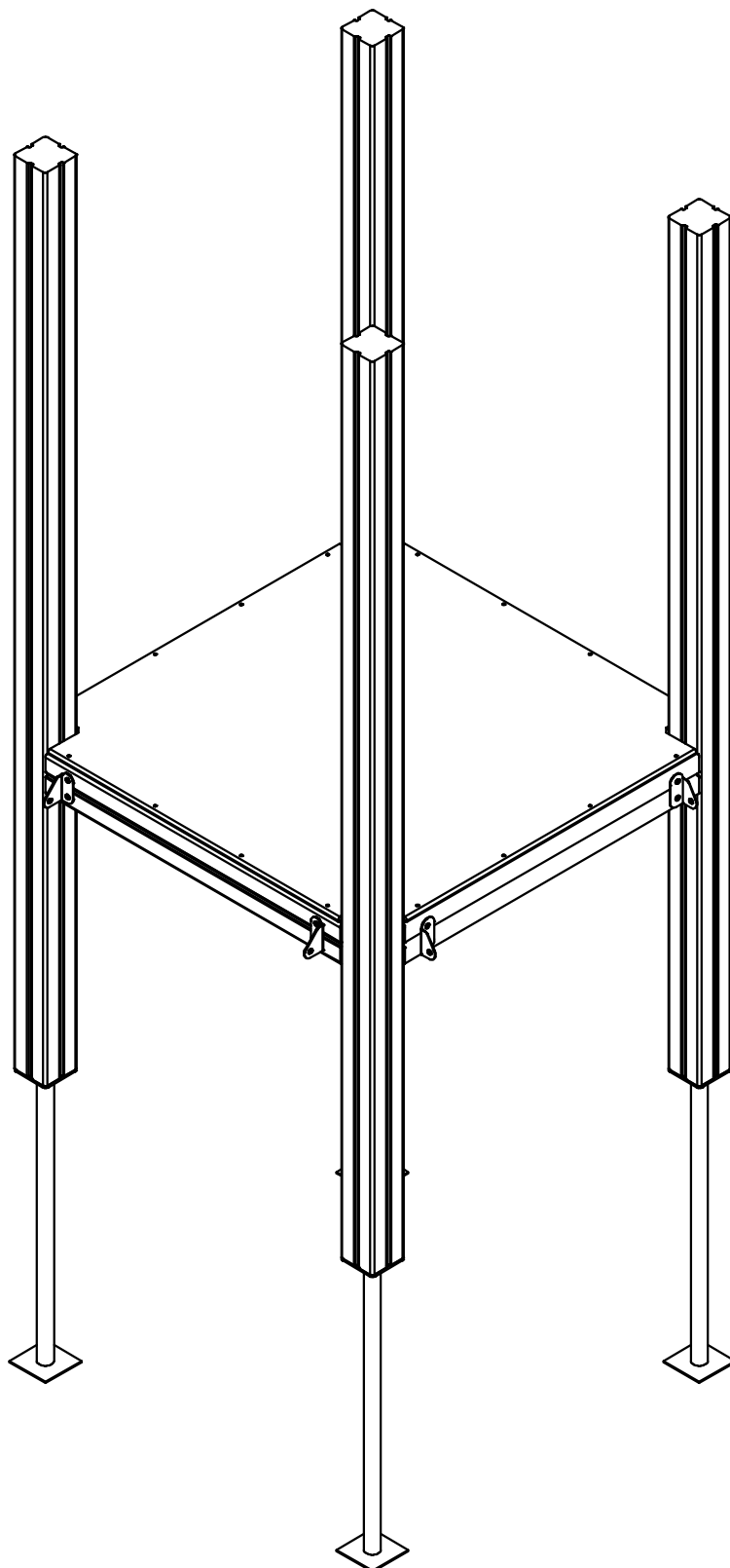

Jūrmalas Mežaparki Ltd.

1 Garkalnes street,
Jūrmala, LV-2011, Latvia







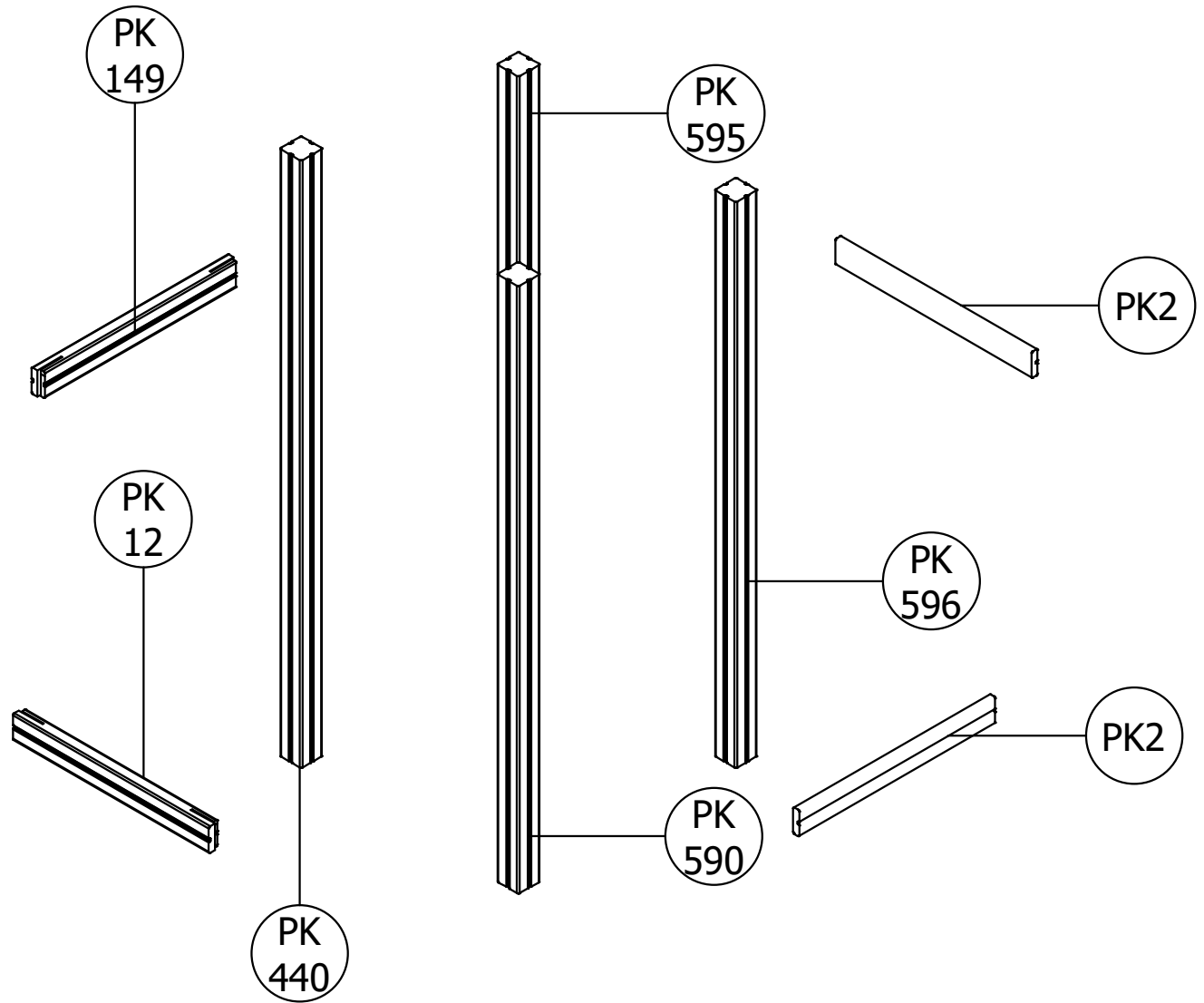



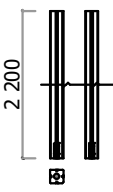
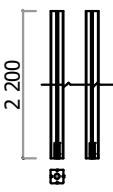
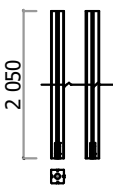
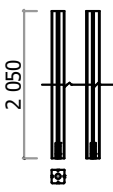
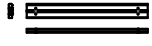

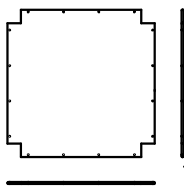

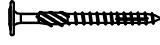
bērnu rotaļu laukumi info@jmp.lv, www.jmp.lv, +371 67732317

EN 9100
BUREAU VERITAS
Certification

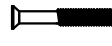



Specification / *Specifikācija* / Osaluettelö

<p>PK590</p>  <p style="text-align: right;">1</p>	<p>PK440</p>  <p style="text-align: right;">1</p>	<p>PK595</p>  <p style="text-align: right;">1</p>	<p>PK596</p>  <p style="text-align: right;">1</p>
<p>PK2</p>  <p style="text-align: right;">2</p>	<p>PK149</p>  <p style="text-align: right;">1</p>	<p>PK12</p>  <p style="text-align: right;">1</p>	<p>NE1</p>  <p style="text-align: right;">1</p>
<p>10</p>  <p style="text-align: right;">16</p>	<p>13</p>  <p style="text-align: right;">4</p>	<p>20</p>  <p style="text-align: right;">16</p>	<p>ME4</p>  <p style="text-align: right;">4</p>
<p>61</p>  <p style="text-align: right;">8</p>	<p>65</p>  <p style="text-align: right;">7</p>	<p>51</p>  <p style="text-align: right;">1</p>	<p>ME6</p>  <p style="text-align: right;">4</p>
<p>92</p>  <p style="text-align: right;">16</p>	<p>97</p>  <p style="text-align: right;">16</p>	<p>100</p>  <p style="text-align: right;">16</p>	<p>101</p>  <p style="text-align: right;">16</p>

Detail steps / *Montāžas soli* / *Asennusvaiheet*

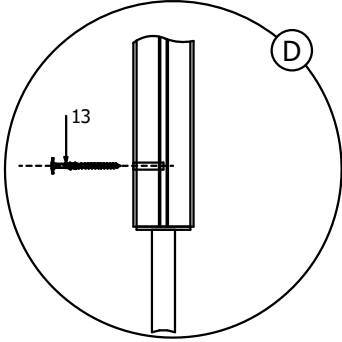
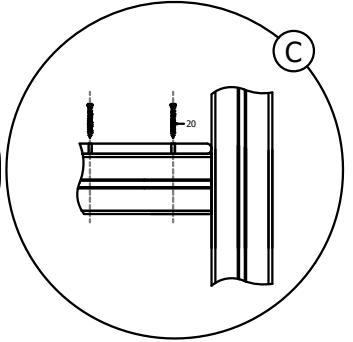
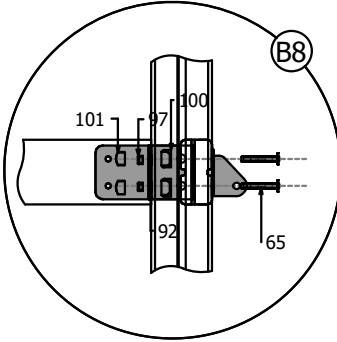
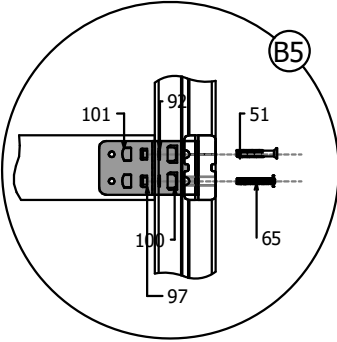
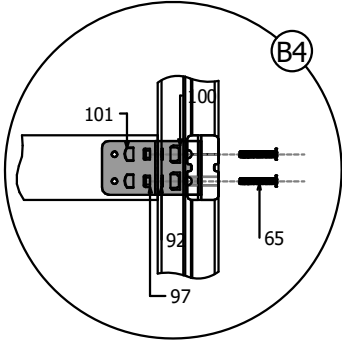
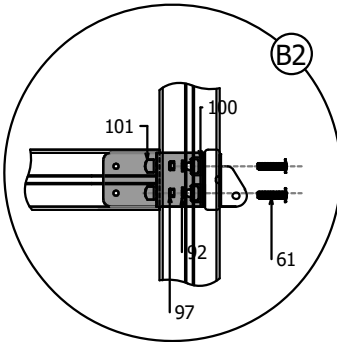
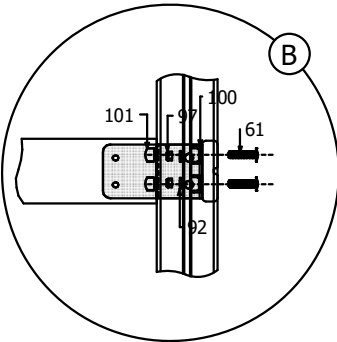
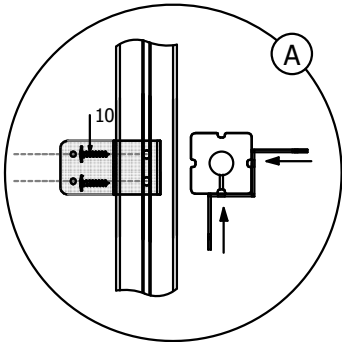

1

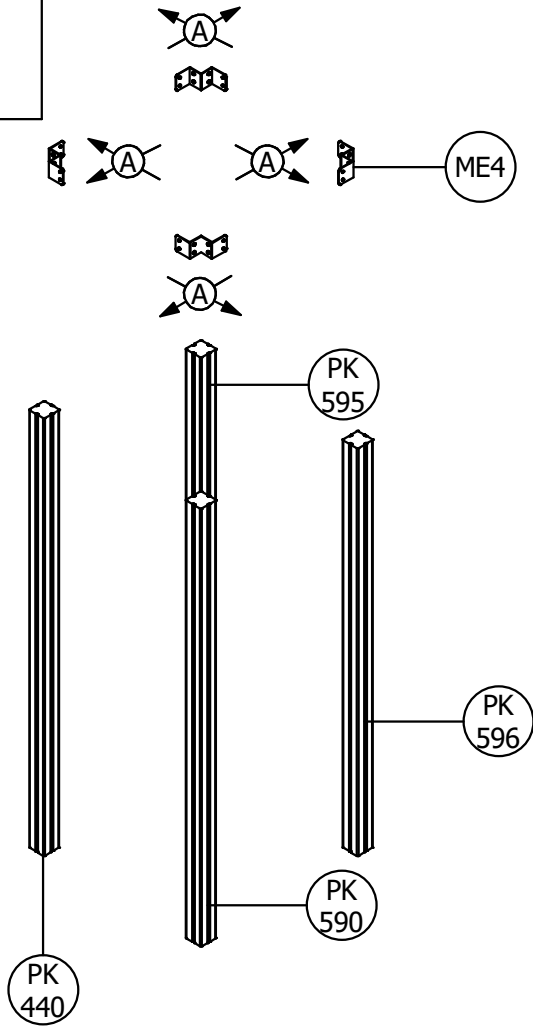

2

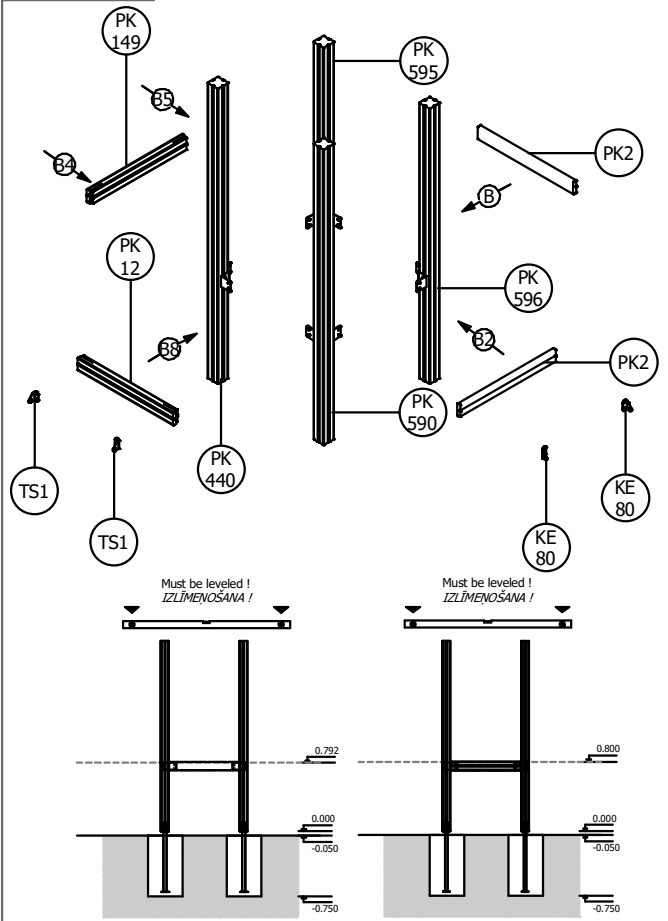

3

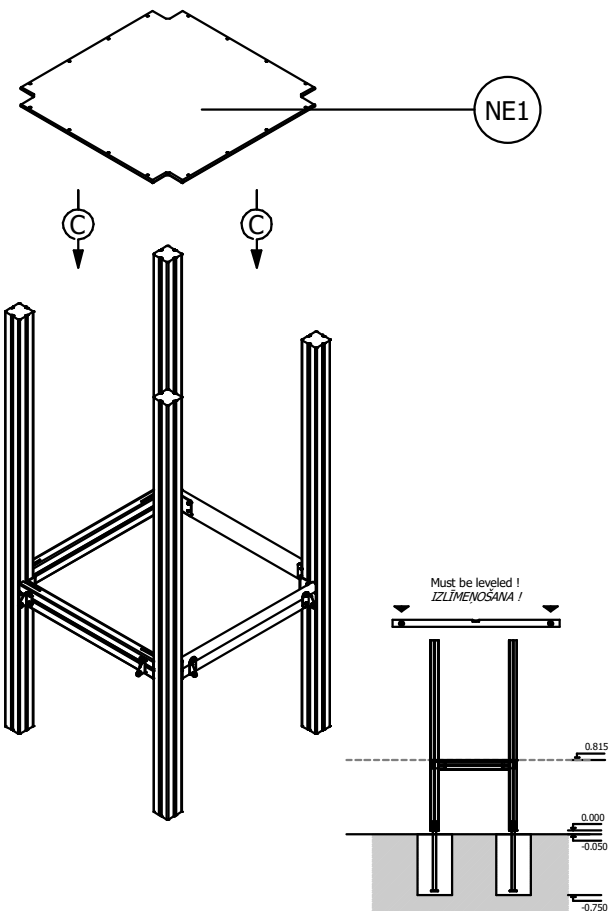

4

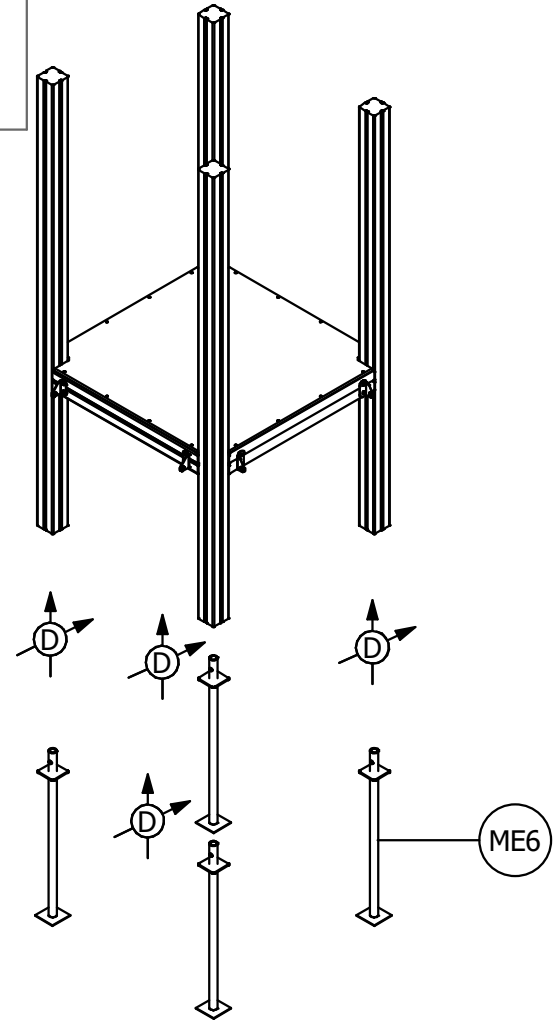

GK-NG-2-E

ASSEMBLY INSTRUCTION

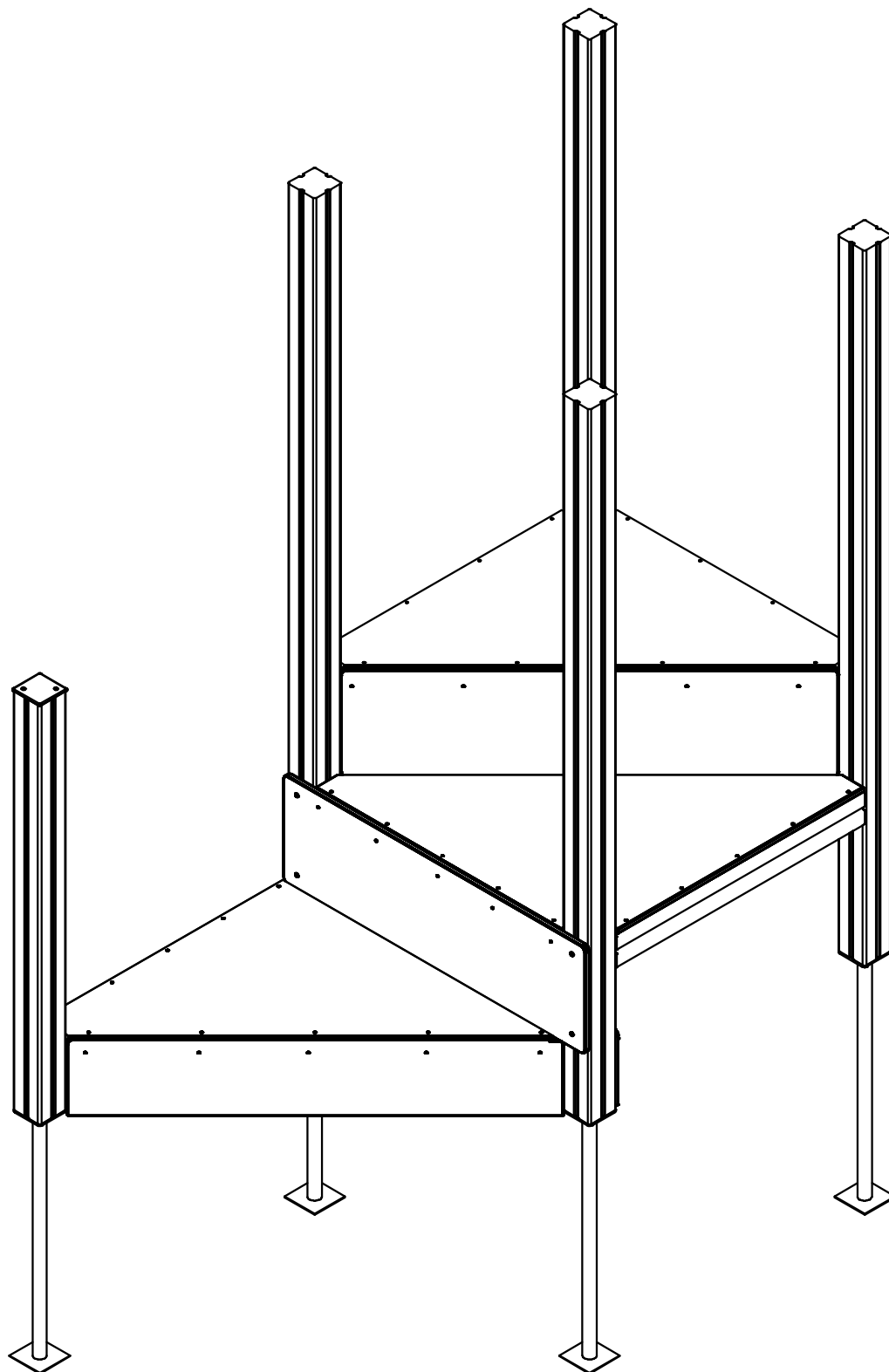

Jūrmalas Mežaparki Ltd.

1 Garkalnes street,
Jūrmala, LV-2011, Latvia

bērnu rotaļu laukumi info@jmp.lv, www.jmp.lv, +371 67732317



EN 9100
BUREAU VERITAS
Certification



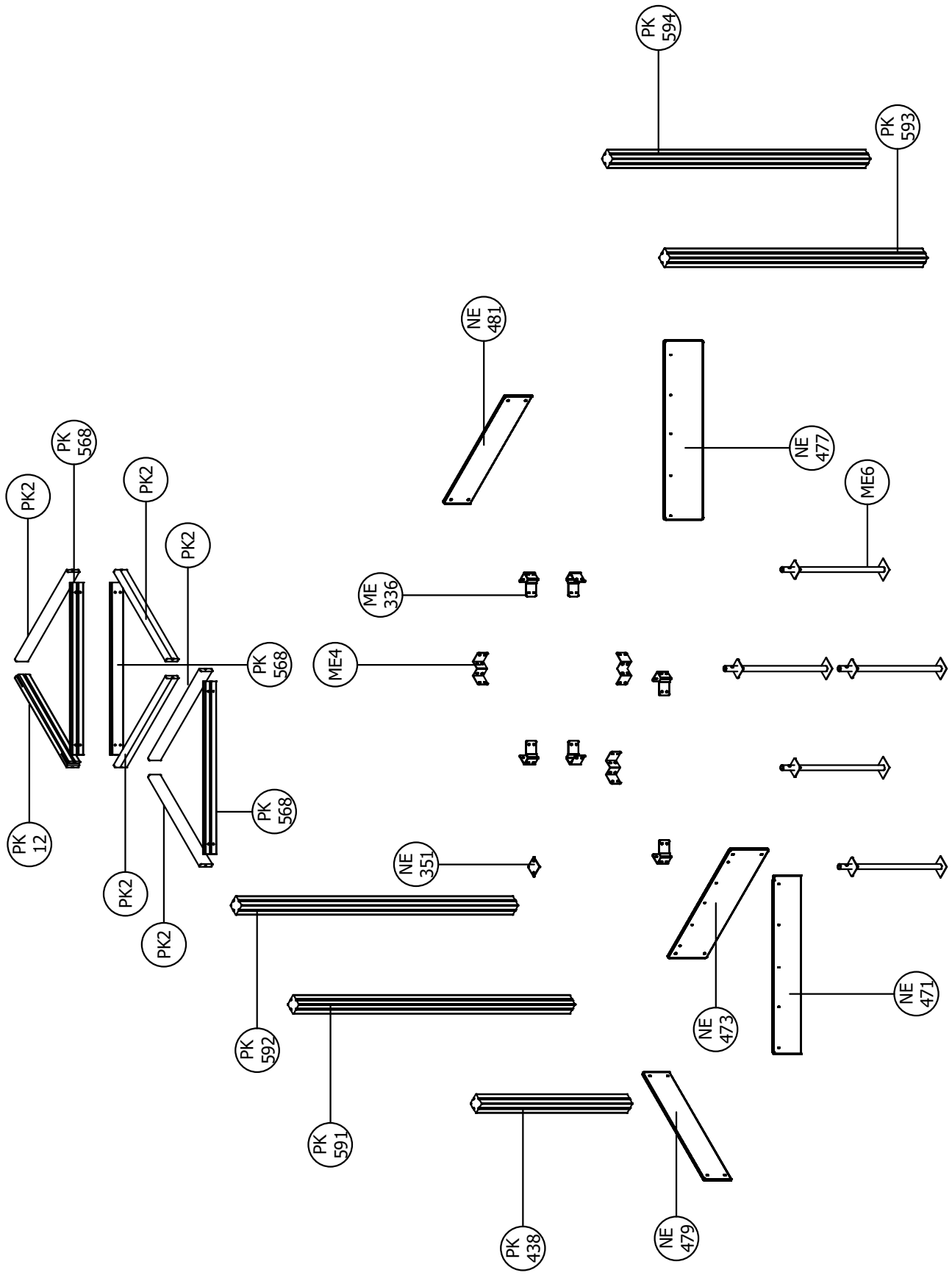



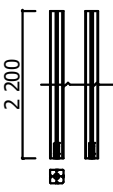
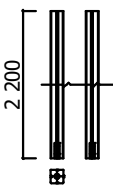
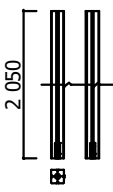
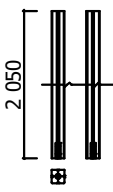
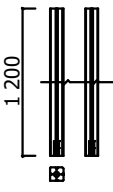
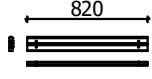

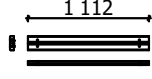
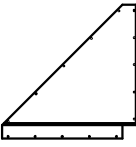
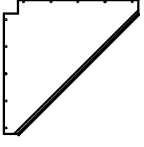
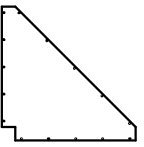
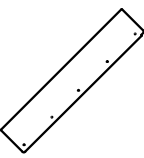
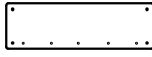
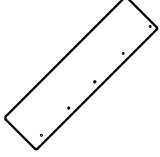
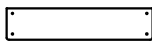
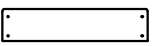
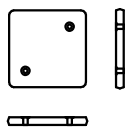





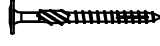

Specification / *Specifikācija* / *Osaluettelo*

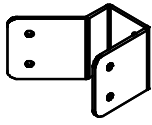

Specification / *Specifikācija* / Osaluettelö

<p>PK591</p>  <p style="text-align: right;">1</p>	<p>PK592</p>  <p style="text-align: right;">1</p>	<p>PK593</p>  <p style="text-align: right;">1</p>	<p>PK594</p>  <p style="text-align: right;">1</p>
<p>PK438</p>  <p style="text-align: right;">1</p>	<p>PK2</p>  <p style="text-align: right;">5</p>	<p>PK12</p>  <p style="text-align: right;">1</p>	<p>PK568</p>  <p style="text-align: right;">3</p>
<p>NE472</p>  <p style="text-align: right;">1</p>	<p>NE476</p>  <p style="text-align: right;">1</p>	<p>NE478</p>  <p style="text-align: right;">1</p>	<p>NE471</p>  <p style="text-align: right;">1</p>
<p>NE473</p>  <p style="text-align: right;">1</p>	<p>NE477</p>  <p style="text-align: right;">1</p>	<p>NE481</p>  <p style="text-align: right;">1</p>	<p>NE479</p>  <p style="text-align: right;">1</p>
<p>NE351</p>  <p style="text-align: right;">1</p>			

Specification / *Specifikācija* / Osaluettelo

<p>3</p>  <p style="text-align: right;">15</p>	<p>10</p>  <p style="text-align: right;">32</p>	<p>13</p>  <p style="text-align: right;">5</p>	<p>ME4</p>  <p style="text-align: right;">3</p>
<p>20</p>  <p style="text-align: right;">40</p>	<p>21</p>  <p style="text-align: right;">2</p>	<p>61</p> <p style="text-align: right;">8 x 40</p>  <p style="text-align: right;">12</p>	<p>ME6</p>  <p style="text-align: right;">5</p>
<p>65</p> <p style="text-align: right;">8 x 60</p>  <p style="text-align: right;">4</p>	<p>57</p> <p style="text-align: right;">8 x 45</p>  <p style="text-align: right;">20</p>	<p>92</p>  <p style="text-align: right;">36</p>	<p>ME336</p>  <p style="text-align: right;">6</p>
<p>97</p>  <p style="text-align: right;">36</p>	<p>100</p>  <p style="text-align: right;">36</p>	<p>101</p>  <p style="text-align: right;">36</p>	

Detail steps / *Montāžas soli* / *Asennusvaiheet*

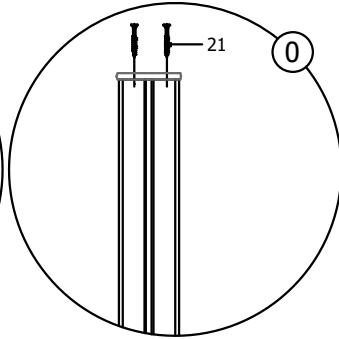
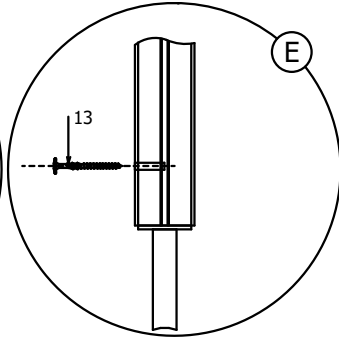
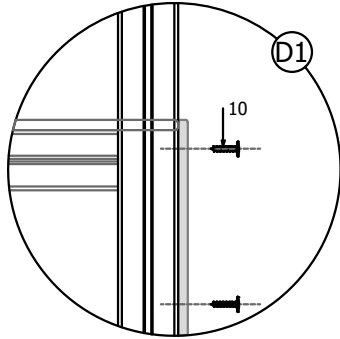
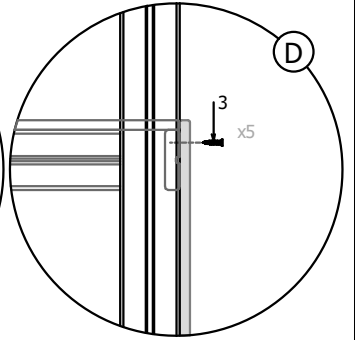
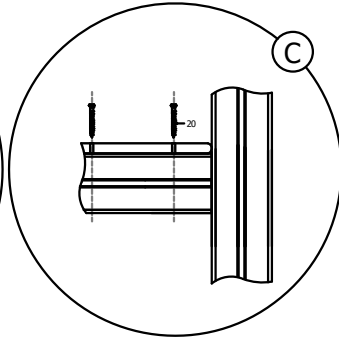
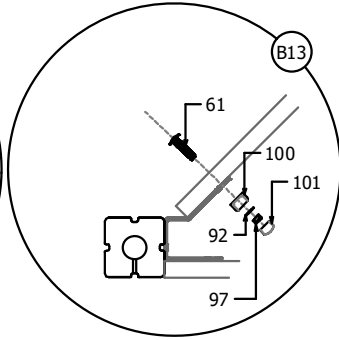
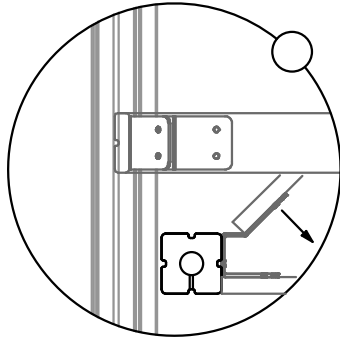
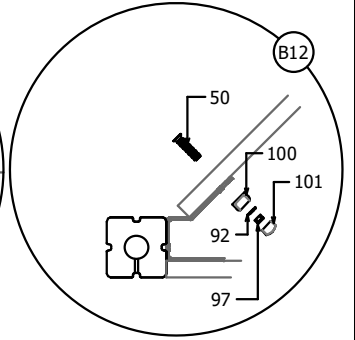
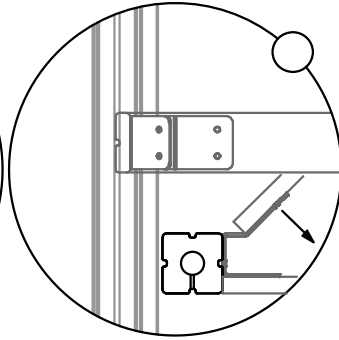
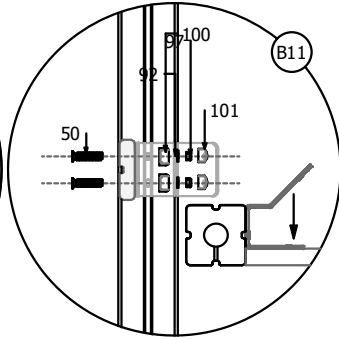
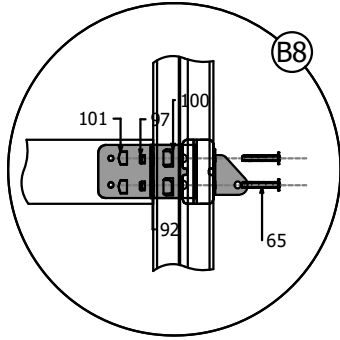
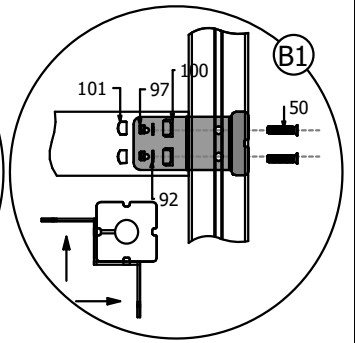
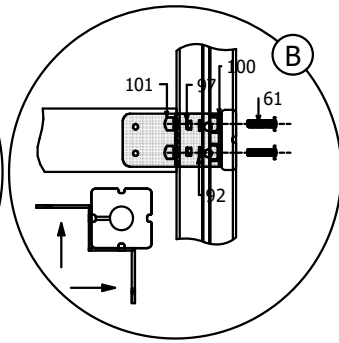
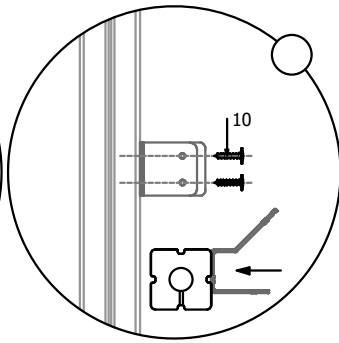
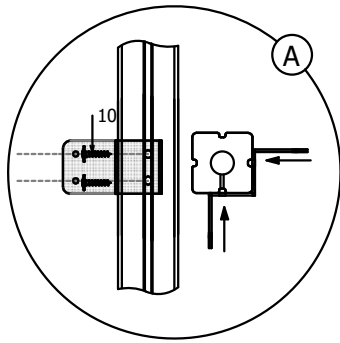

1

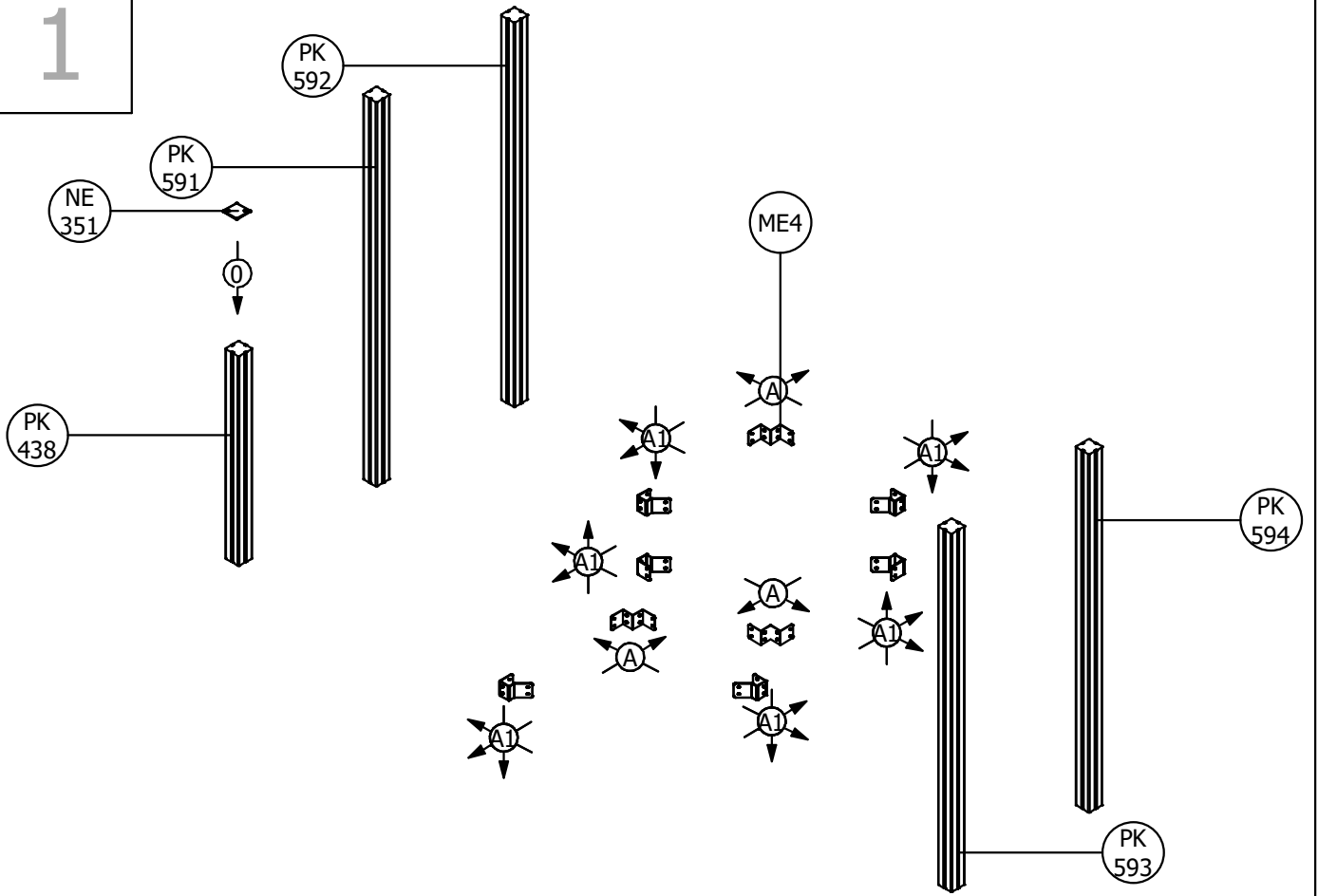

2

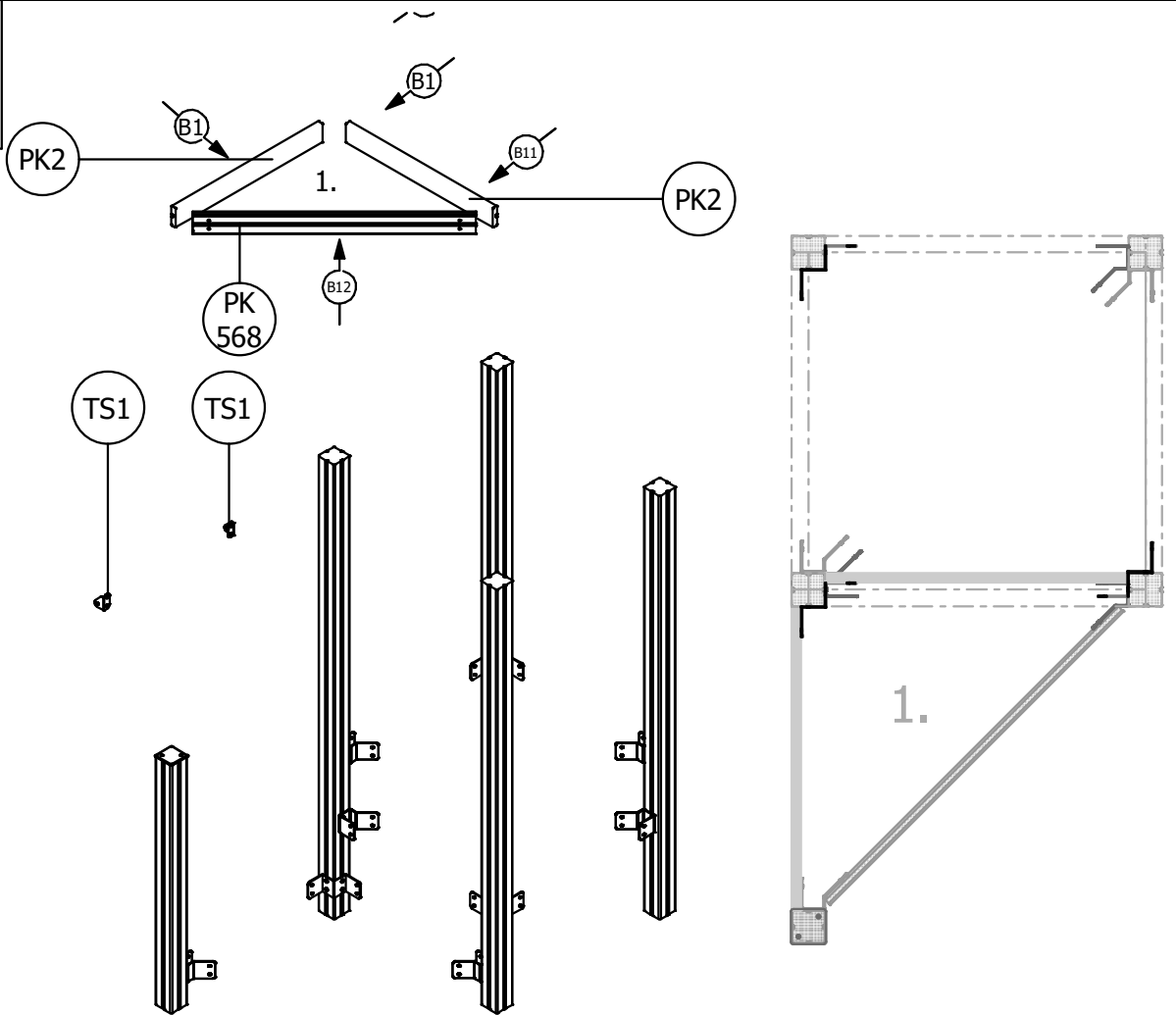

3

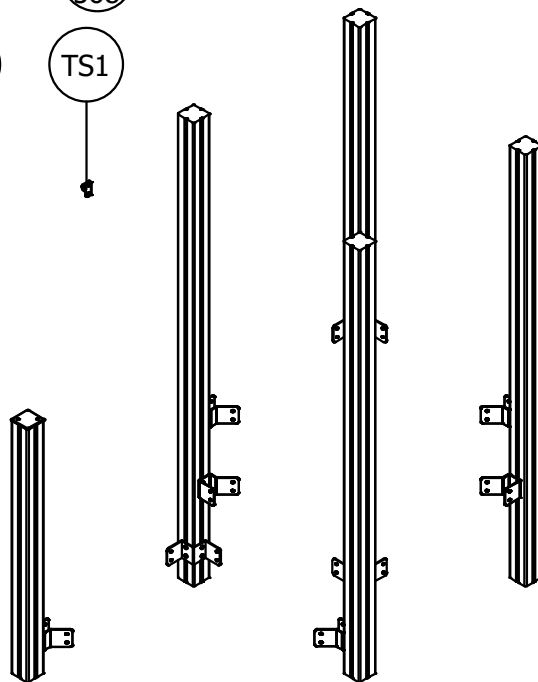
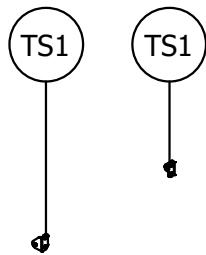
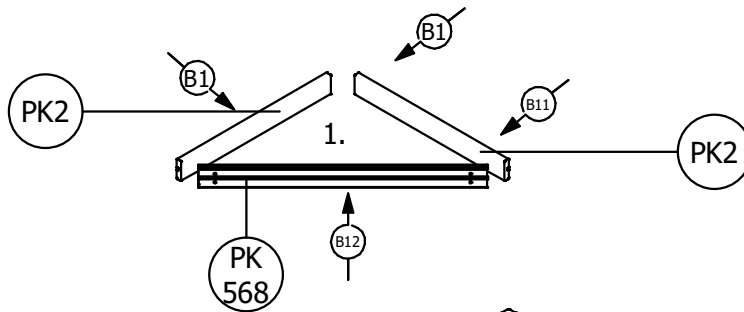
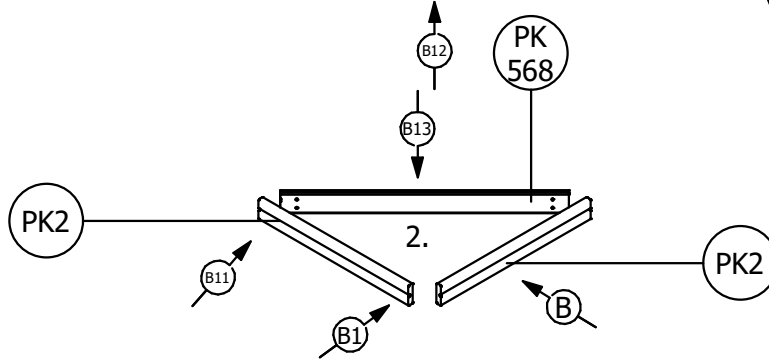
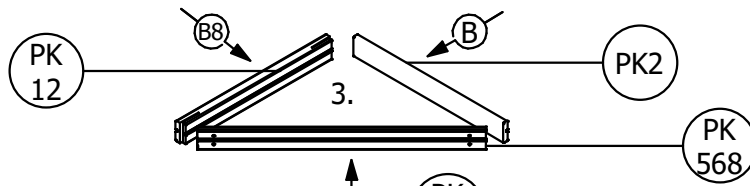
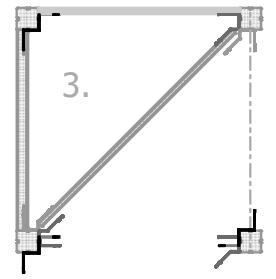
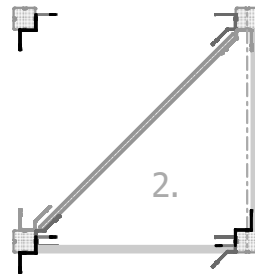
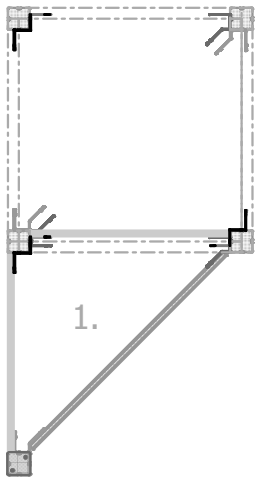

5

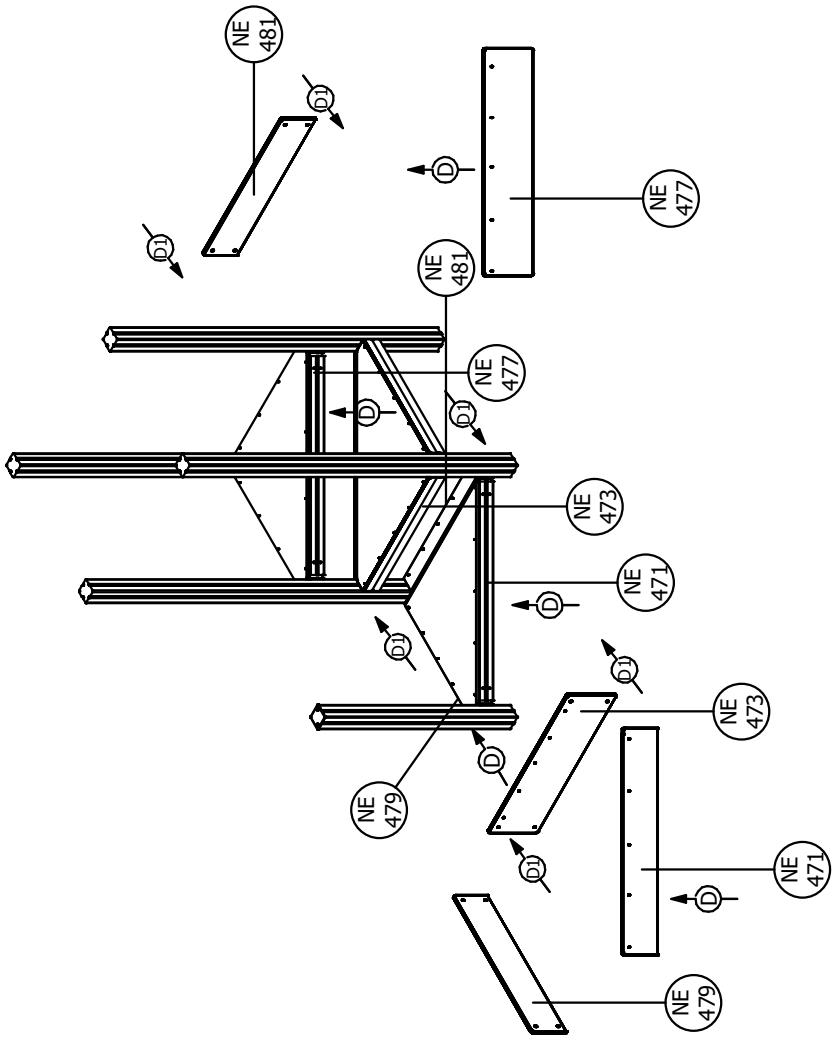

4

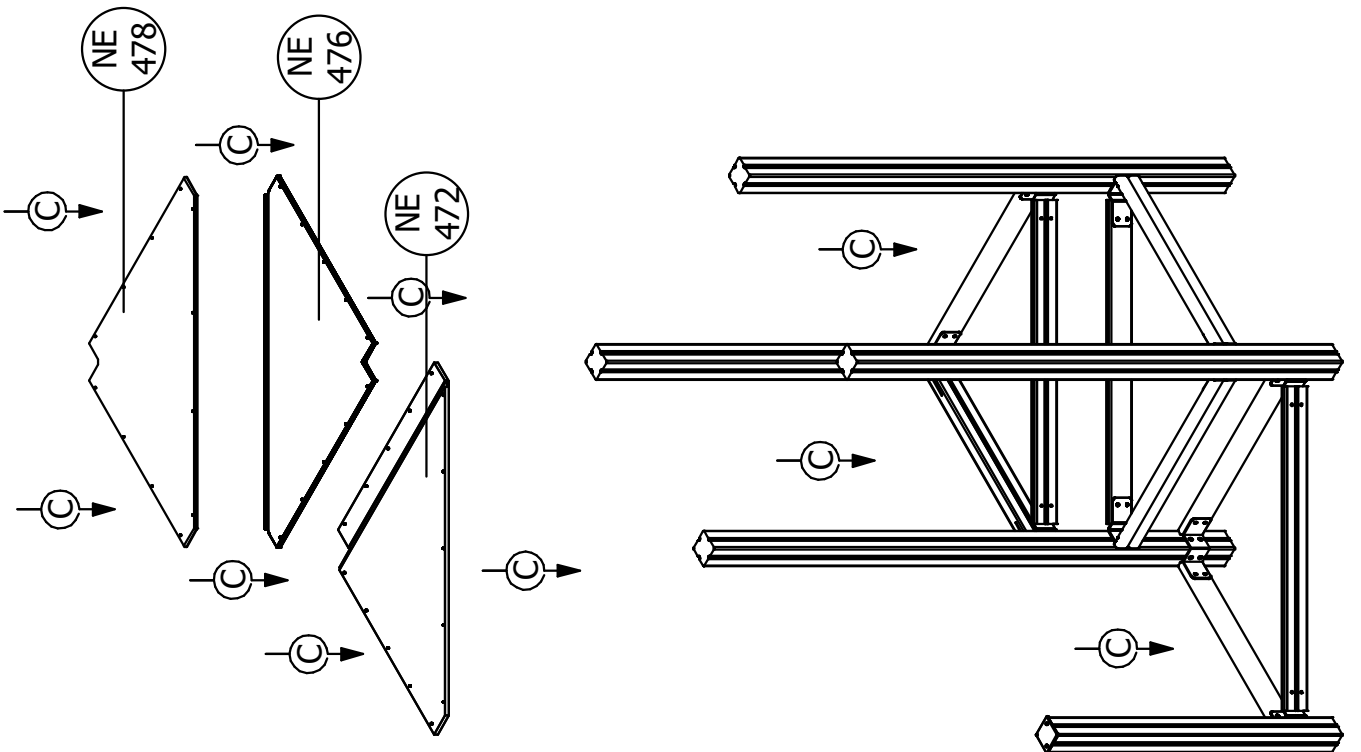

6

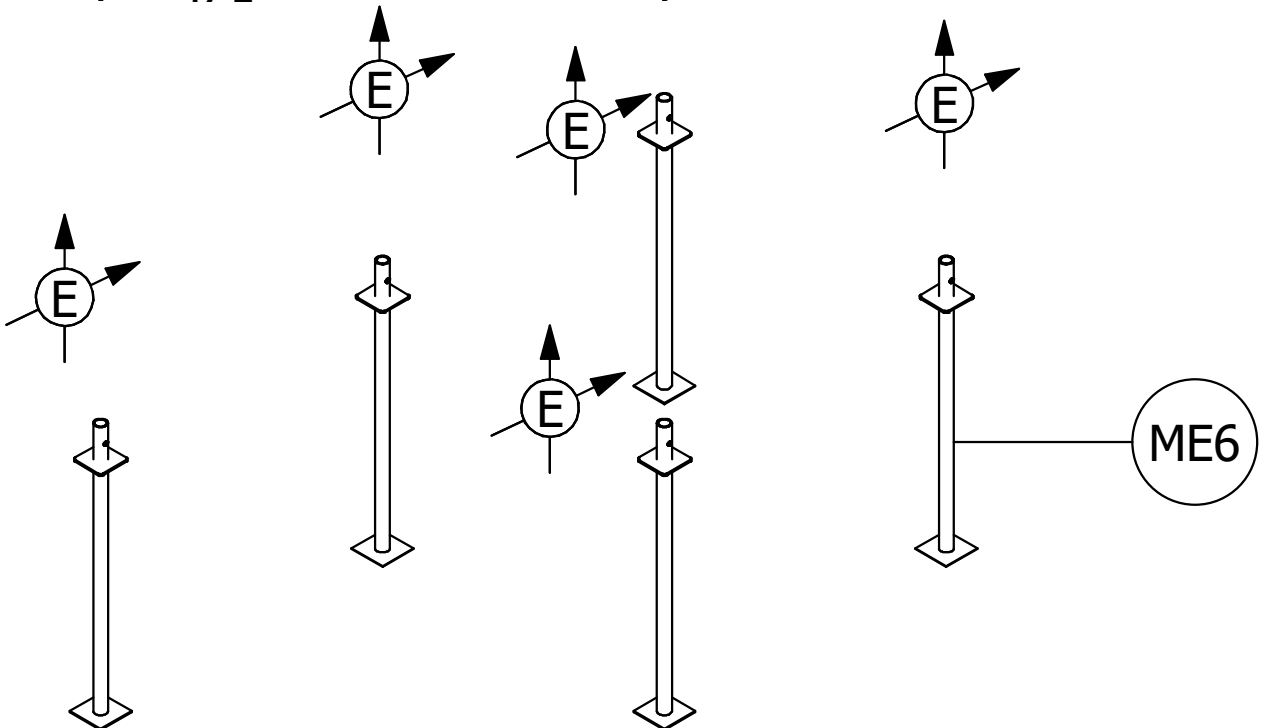
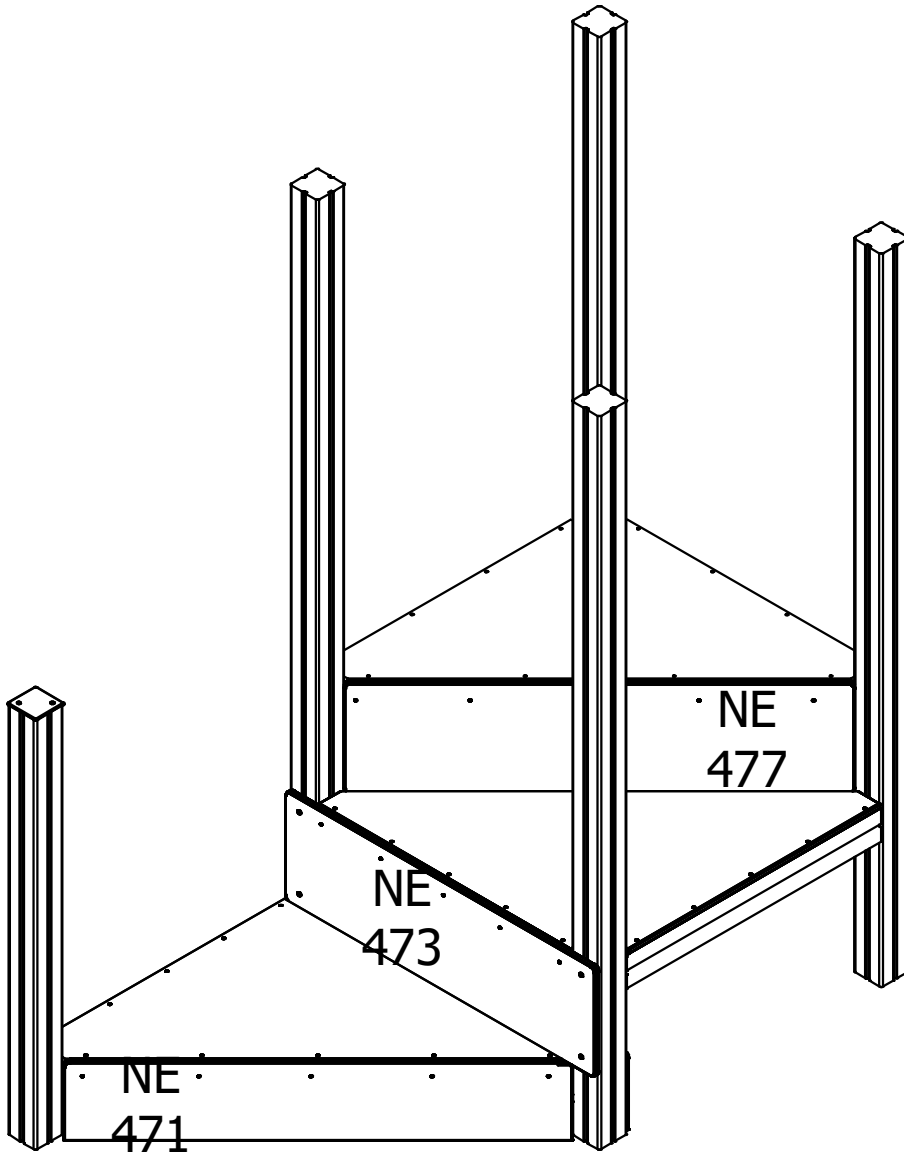

X2142-E

ASSEMBLY INSTRUCTION

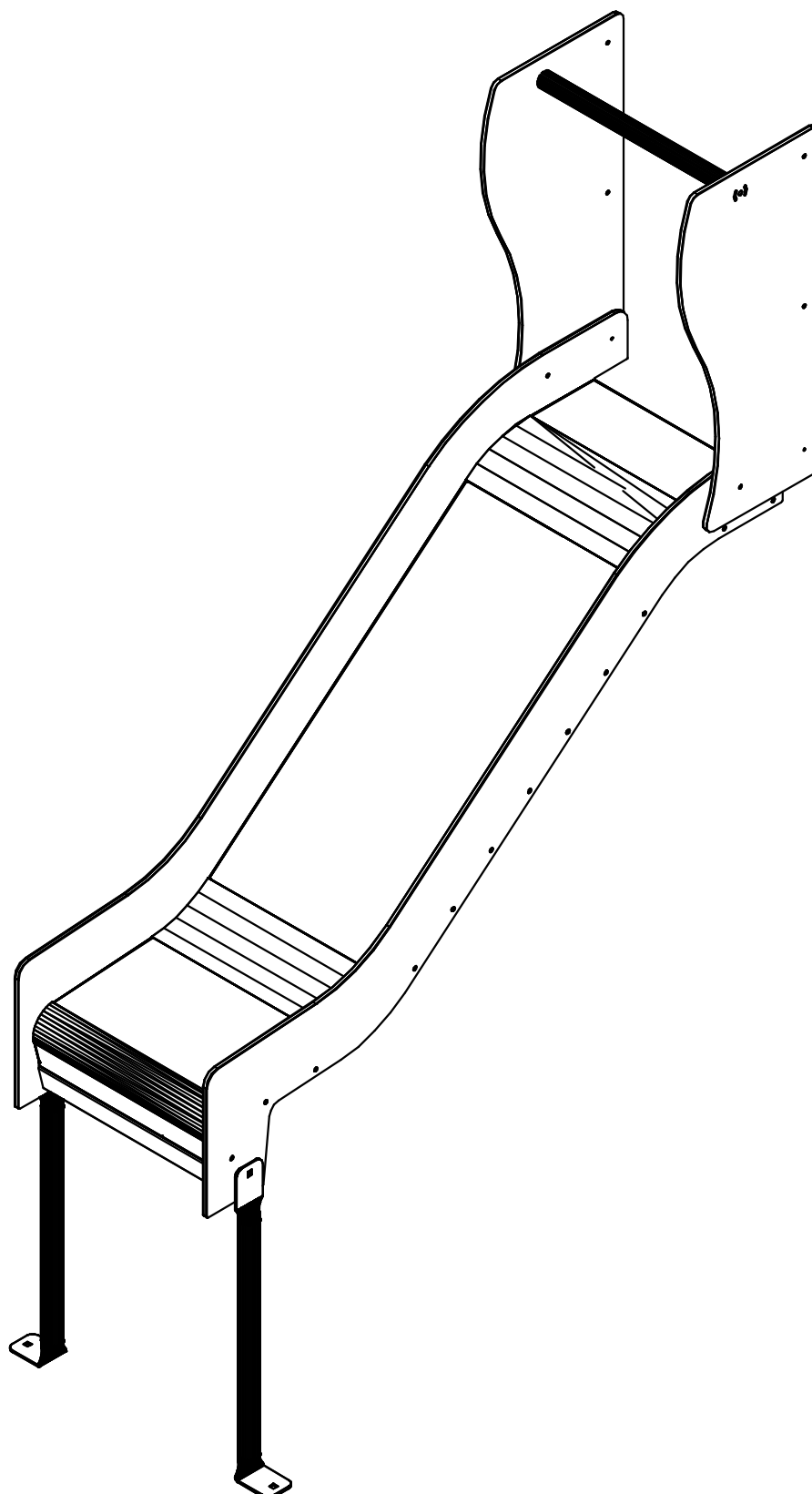

Jūrmalas Mežaparki Ltd.

1 Garkalnes street,
Jūrmala, LV-2011, Latvia







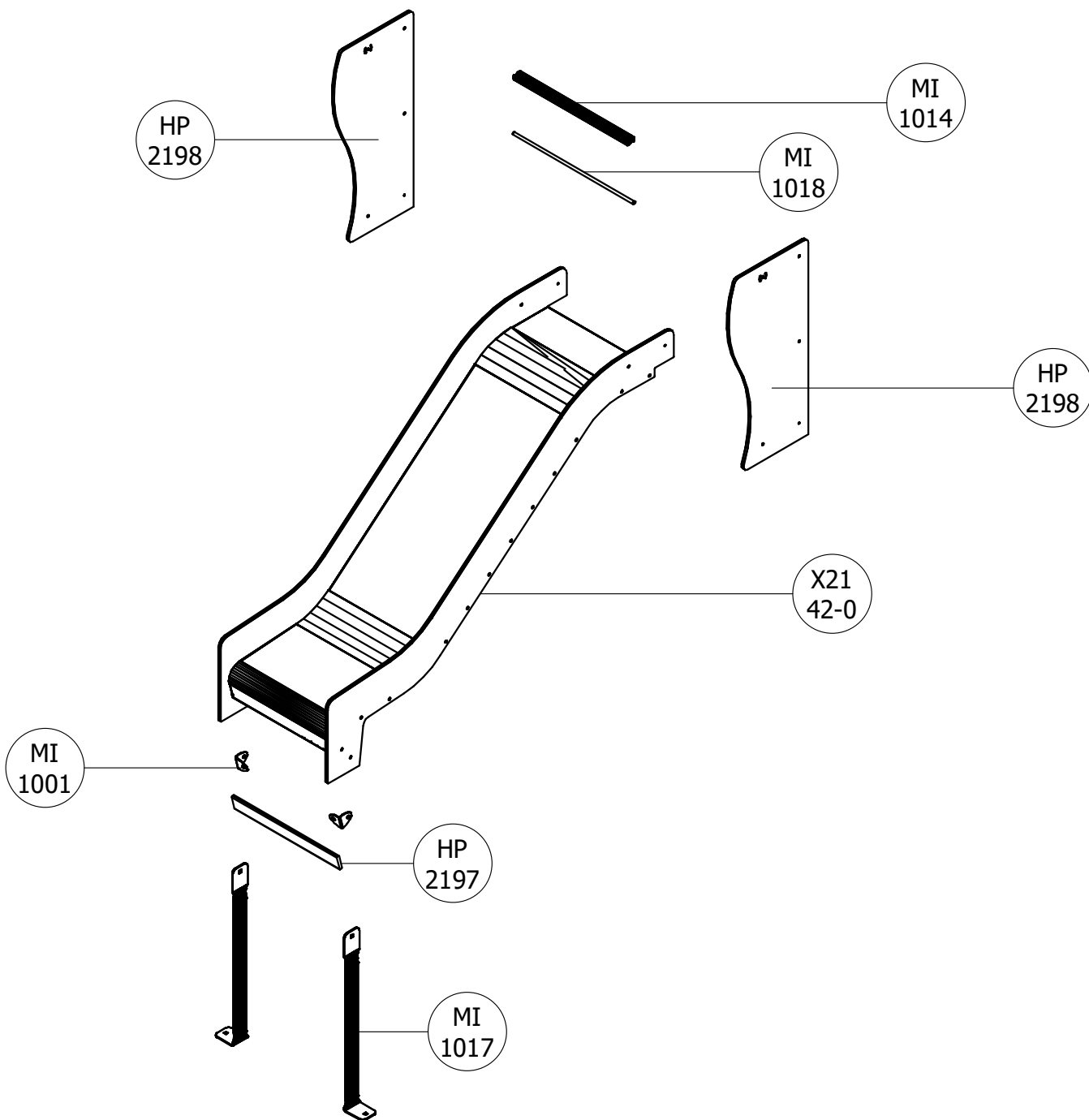



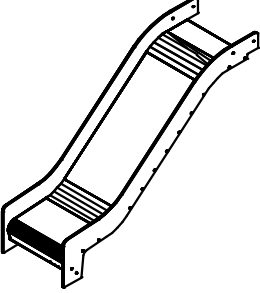







bērnu rotaļu laukumi info@jmp.lv, www.jmp.lv, +371 67732317

EN 9100
BUREAU VERITAS
Certification





Specification / *Specifikācija* / Osaluettelo

<p>X2142-0</p>  <p style="text-align: right;">1</p>	<p>HP2198</p>  <p style="text-align: right;">2</p>	<p>HP2197</p>  <p style="text-align: right;">1</p>	<p>MI1001</p>  <p style="text-align: right;">2</p>
<p>14</p>  <p style="text-align: right;">2</p>	<p>8 x 50</p> <p>23</p>  <p style="text-align: right;">2</p>	<p>5 x 50</p> <p>MI1017</p>  <p style="text-align: right;">2</p>	<p>MI1014</p>  <p style="text-align: right;">1</p>
<p>60</p> <p>8 x 35</p>  <p style="text-align: right;">2</p>	<p>169</p> <p>8 x 25</p>  <p style="text-align: right;">2</p>	<p>236</p> <p>8 x 30</p>  <p style="text-align: right;">2</p>	<p>MI1018</p>  <p style="text-align: right;">1</p>
<p>92</p>  <p style="text-align: right;">2</p>	<p>95</p>  <p style="text-align: right;">4</p>	<p>97</p>  <p style="text-align: right;">7</p>	<p>100</p>  <p style="text-align: right;">2</p>
<p>101</p>  <p style="text-align: right;">2</p>	<p>102</p>  <p style="text-align: right;">4</p>	<p>103</p>  <p style="text-align: right;">4</p>	

Detail steps / *Montāžas soli* / *Asennusvaiheet*

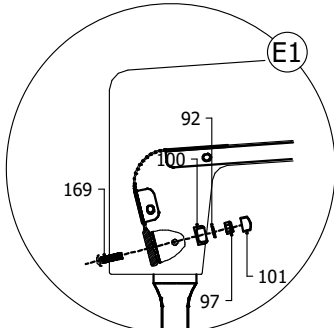
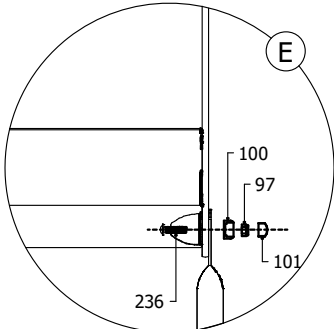
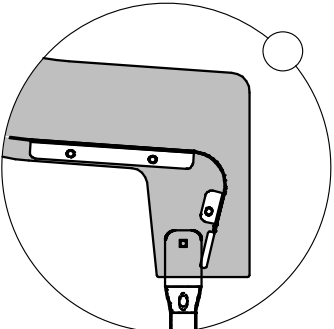
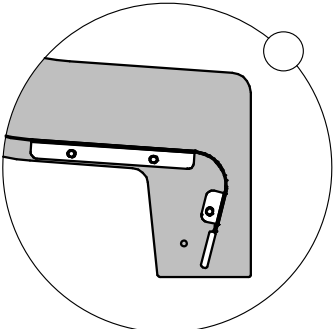
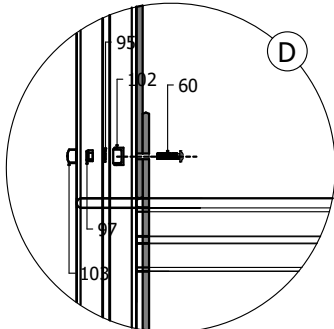
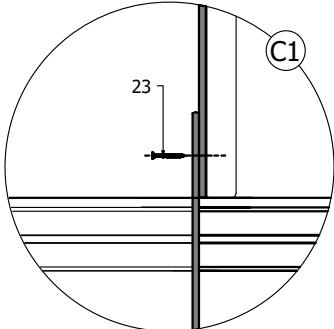
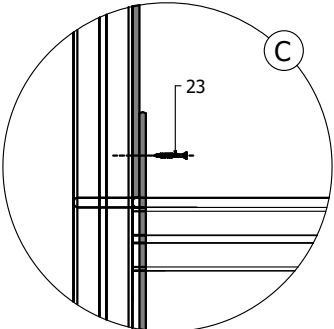
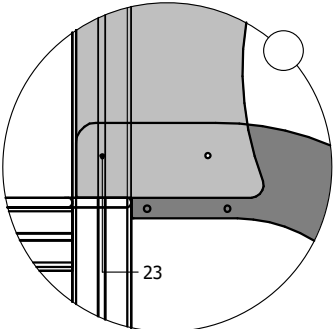
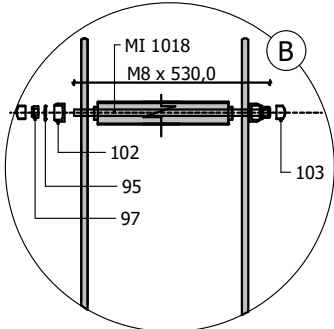
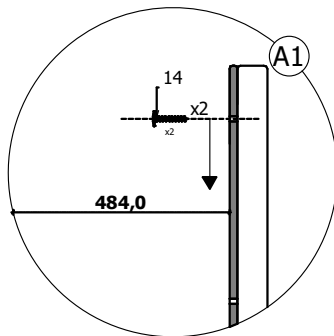
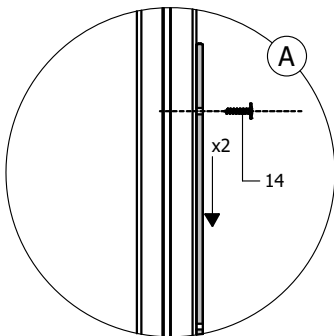
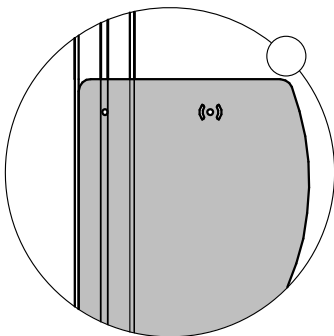
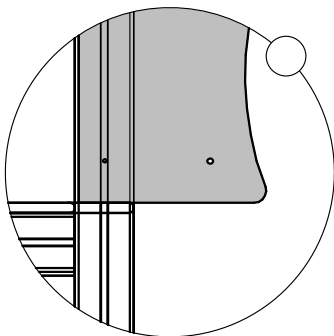

1

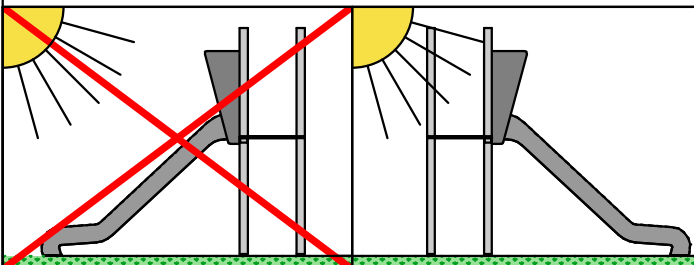
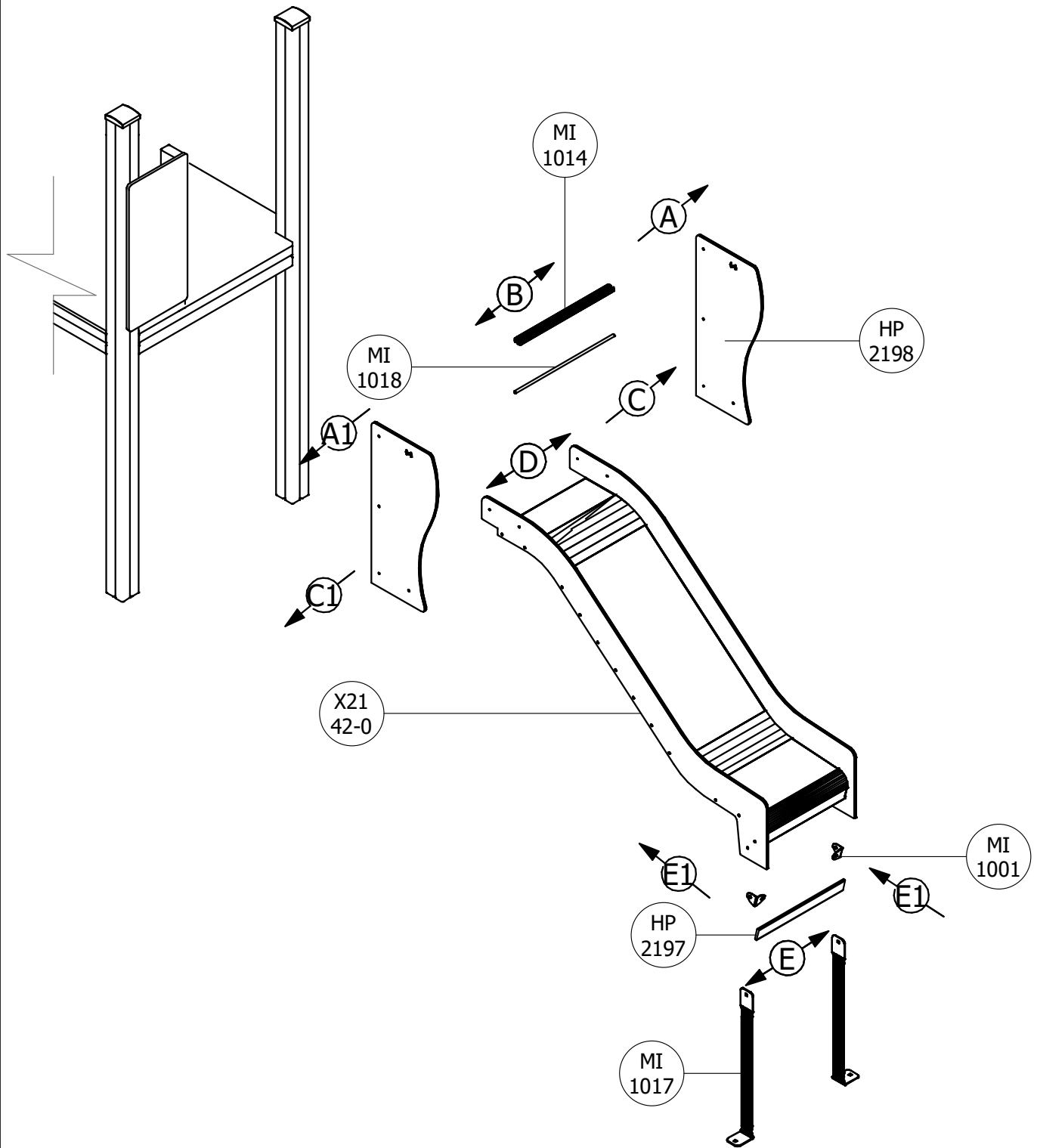

The slide should be positioned so, that the slope does not face south to reduce absorbed heat from the sun!

Slidkalniņš jānovieto tā, lai slīdvirsma nebūtu tiešā saules ietekmē!

Vältā asentamasta liukua suoraan auringon paisteeseen kuumuuden välttämiseksi.

JK6-E

ASSEMBLY INSTRUCTION

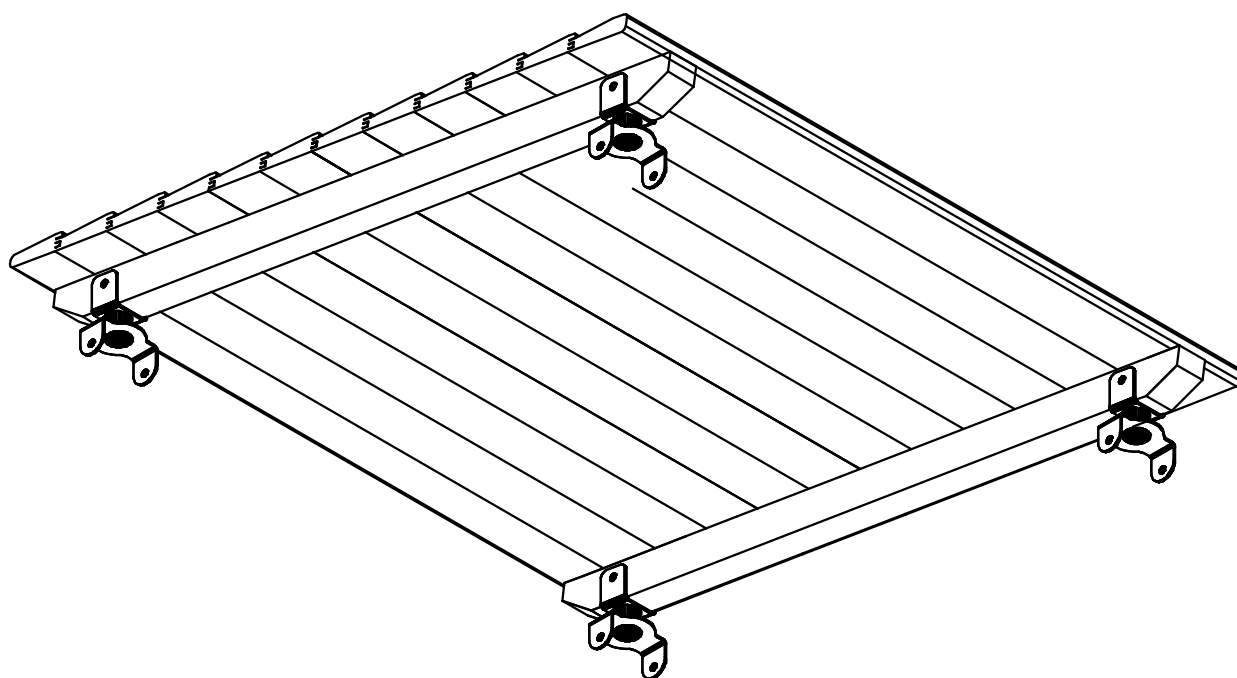

Jūrmalas Mežaparki Ltd.

1 Garkalnes street,
Jūrmala, LV-2011, Latvia







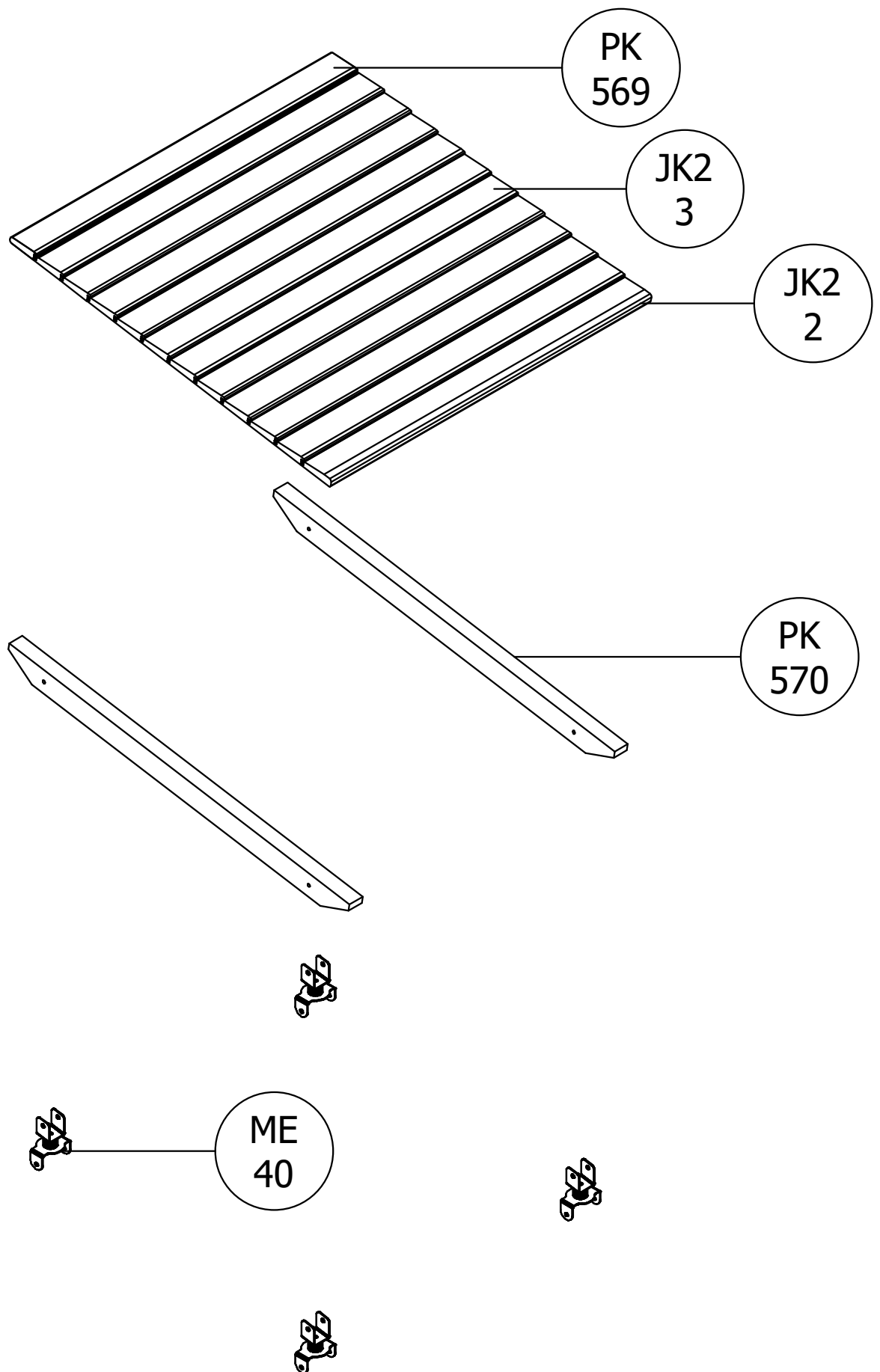

bērnu rotaļu laukumi info@jmp.lv, www.jmp.lv, +371 67732317

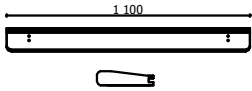
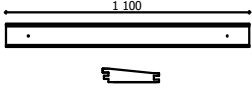
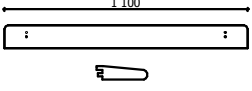
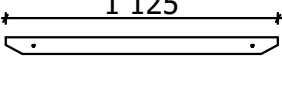
EN 9100
BUREAU VERITAS
Certification





Specification / *Specifikācija* / Osaluettelo

<p>JK2-2</p>  <p style="text-align: right;">1</p>	<p>JK2-3</p>  <p style="text-align: right;">10</p>	<p>PK569</p>  <p style="text-align: right;">1</p>	<p>PK570</p>  <p style="text-align: right;">2</p>
<p>10</p> <p style="text-align: right;">8 x 40</p>  <p style="text-align: right;">8</p>	<p>23</p> <p style="text-align: right;">5 x 50</p>  <p style="text-align: right;">32</p>	<p>66</p> <p style="text-align: right;">8 x 65</p>  <p style="text-align: right;">4</p>	<p>ME40</p>  <p style="text-align: right;">4</p>
<p>92</p>  <p style="text-align: right;">4</p>	<p>97</p>  <p style="text-align: right;">4</p>	<p>100</p>  <p style="text-align: right;">4</p>	<p>101</p>  <p style="text-align: right;">4</p>

Detail steps / *Montāžas soļi* / Asennusvaiheet

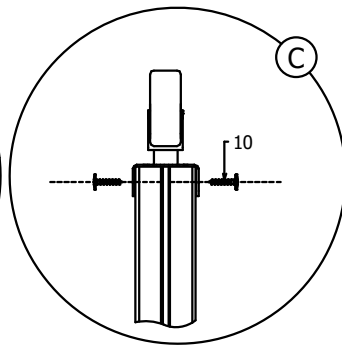
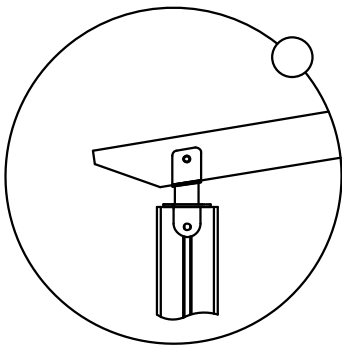
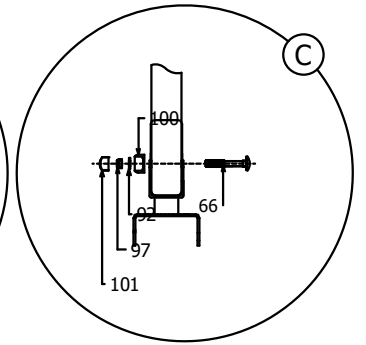
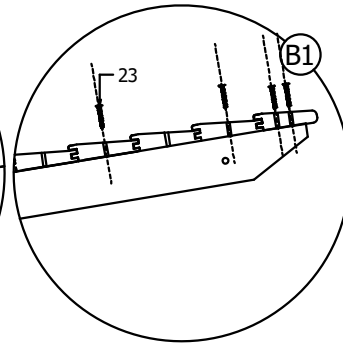
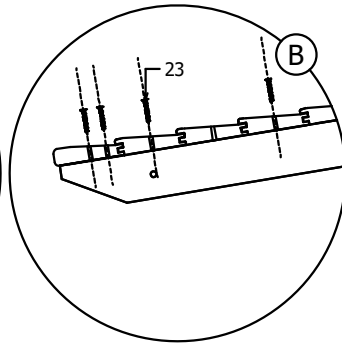
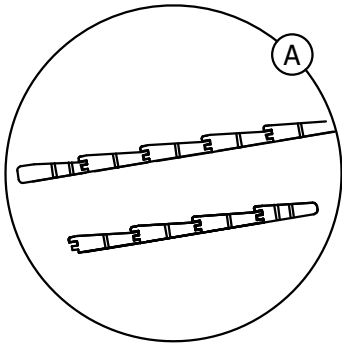

2

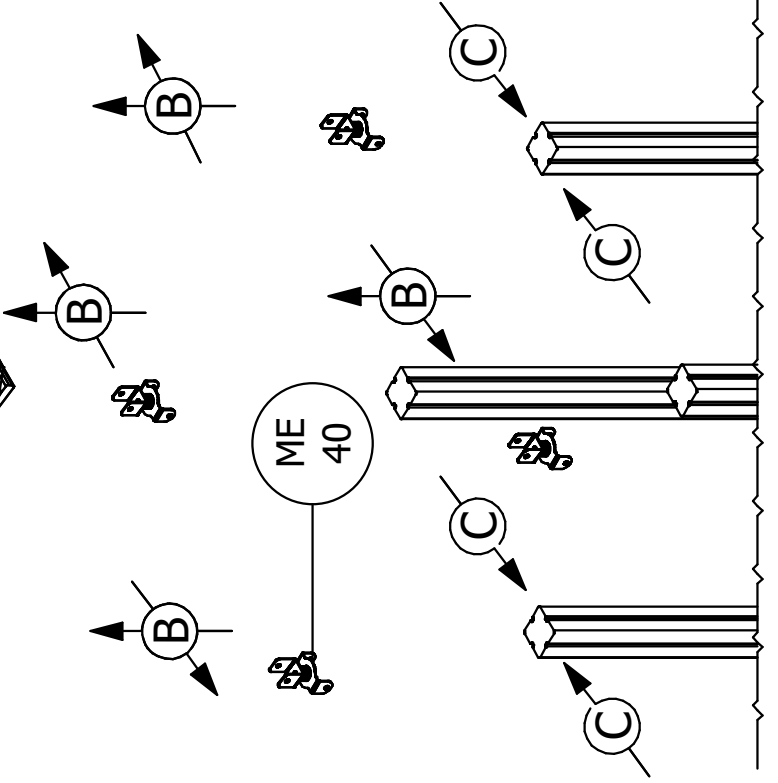
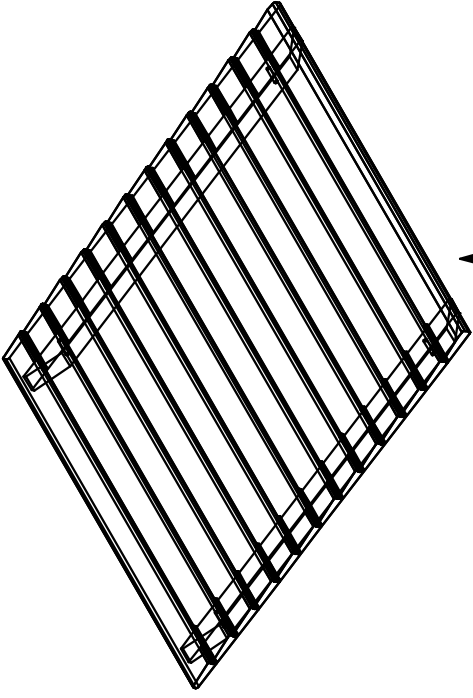

1

