

A

B

C

D

E

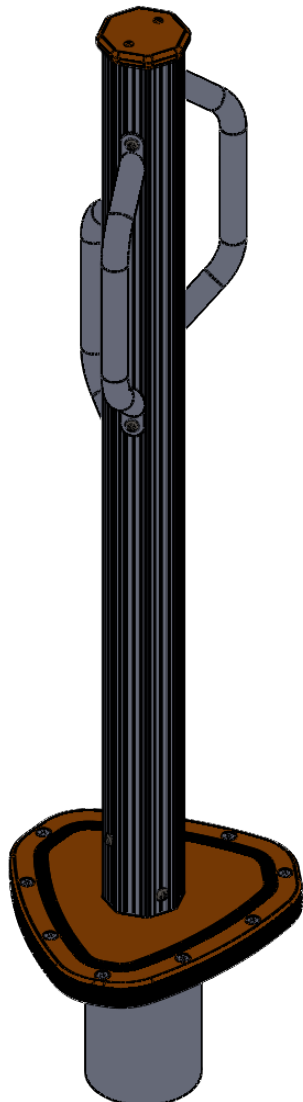

UNLESS OTHERWISE SPECIFIED:
 DIMENSIONS ARE IN MILLIMETERS
 WEIGHT ARE IN KILOGRAMM

PART NUMBER / DWG NO.: **OCT001**

	NAME	SIGNATURE	DATE	REVISION
DRAWN	M. Kalamees		6/18/2019	
APPV'D				

DESCRIPTION:
Spinner

Tiptiptap OÜ
 Jüri alevik, Rae vald,
 75301 Harjumaa

MATERIAL:	metal, plastic	A4
WEIGHT:	SCALE: 1:10	SHEET 1 OF 4

safety area

A

B

C

D

E

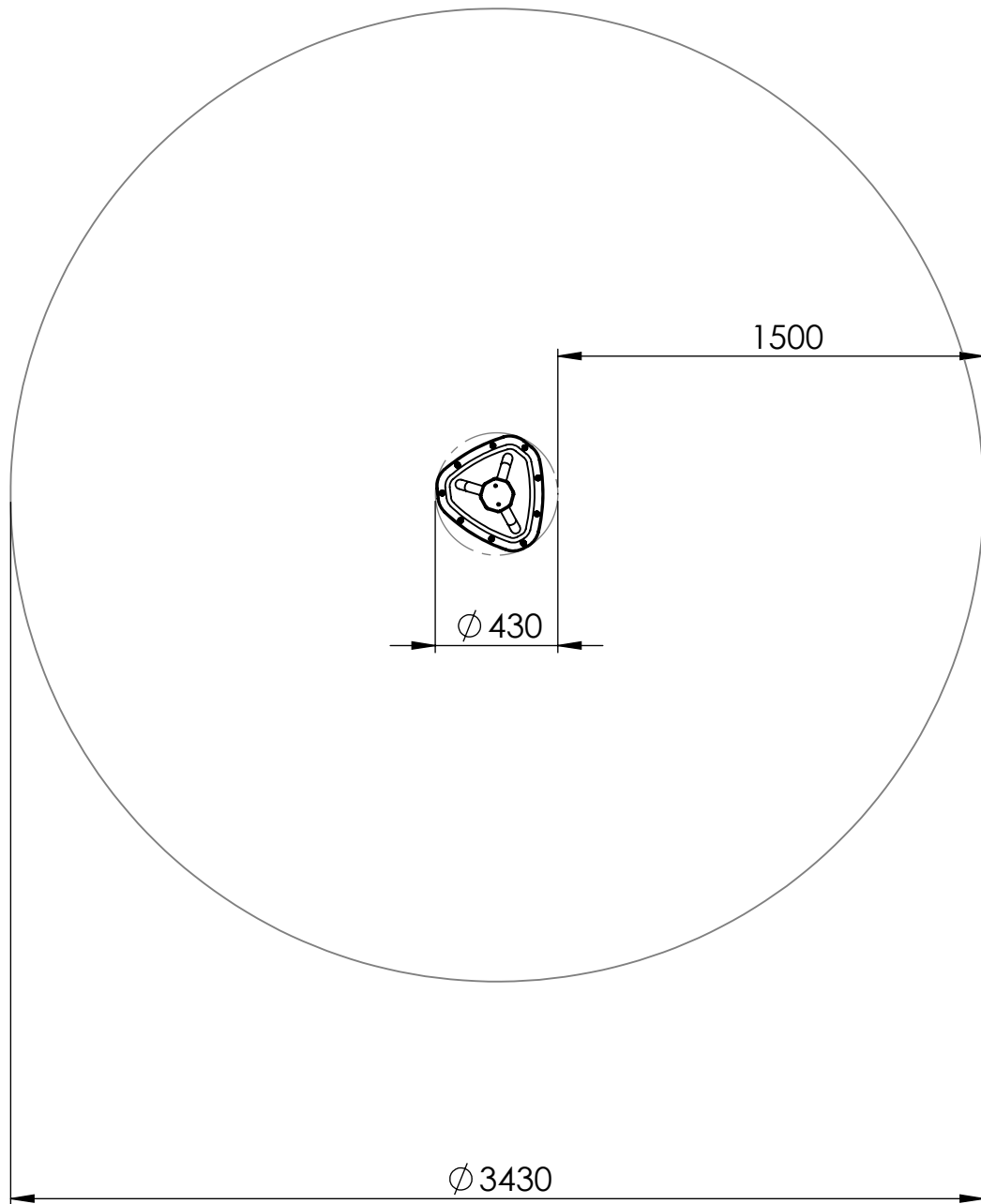

UNLESS OTHERWISE SPECIFIED:
DIMENSIONS ARE IN MILLIMETERS
WEIGHT ARE IN KILOGRAMM

PART NUMBER / DWG NO.:

OCT001

	NAME	SIGNATURE	DATE	REVISION
DRAWN	M. Kalamees		6/18/2019	
APPV'D				

DESCRIPTION:

Spinner

F



Tiptaptap OÜ

Tiptaptap OÜ
Veetorni 9,
Jüri alevik, Rae vald,
75301 Harjumaa

MATERIAL:

metal, plastic

A4

WEIGHT:

SCALE: 1:25

SHEET 2 OF 4

foundation

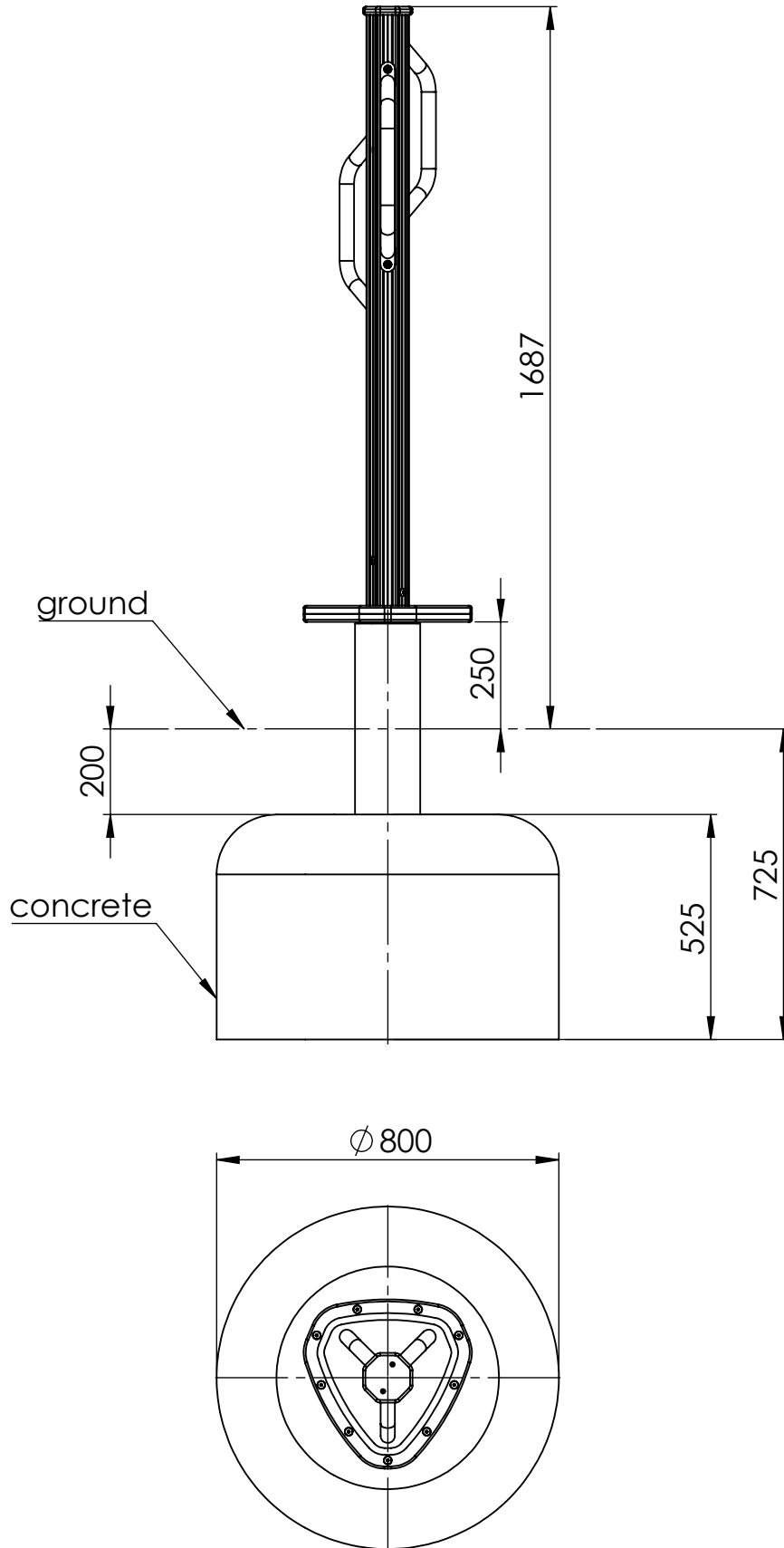

UNLESS OTHERWISE SPECIFIED:
DIMENSIONS ARE IN MILLIMETERS
WEIGHT ARE IN KILOGRAMM

PART NUMBER / DWG NO.:

OCT001

	NAME	SIGNATURE	DATE	REVISION
DRAWN	M. Kalamees		6/18/2019	
APPV'D				

DESCRIPTION:

Spinner

MATERIAL:

metal, plastic

A4

WEIGHT:

SCALE: 1:16

SHEET 3 OF 4



Tiptiptap OÜ

Tiptiptap OÜ
Veetorni 9,
Jüri alevik, Rae vald,
75301 Harjumaa

A

B

C

D

E

F

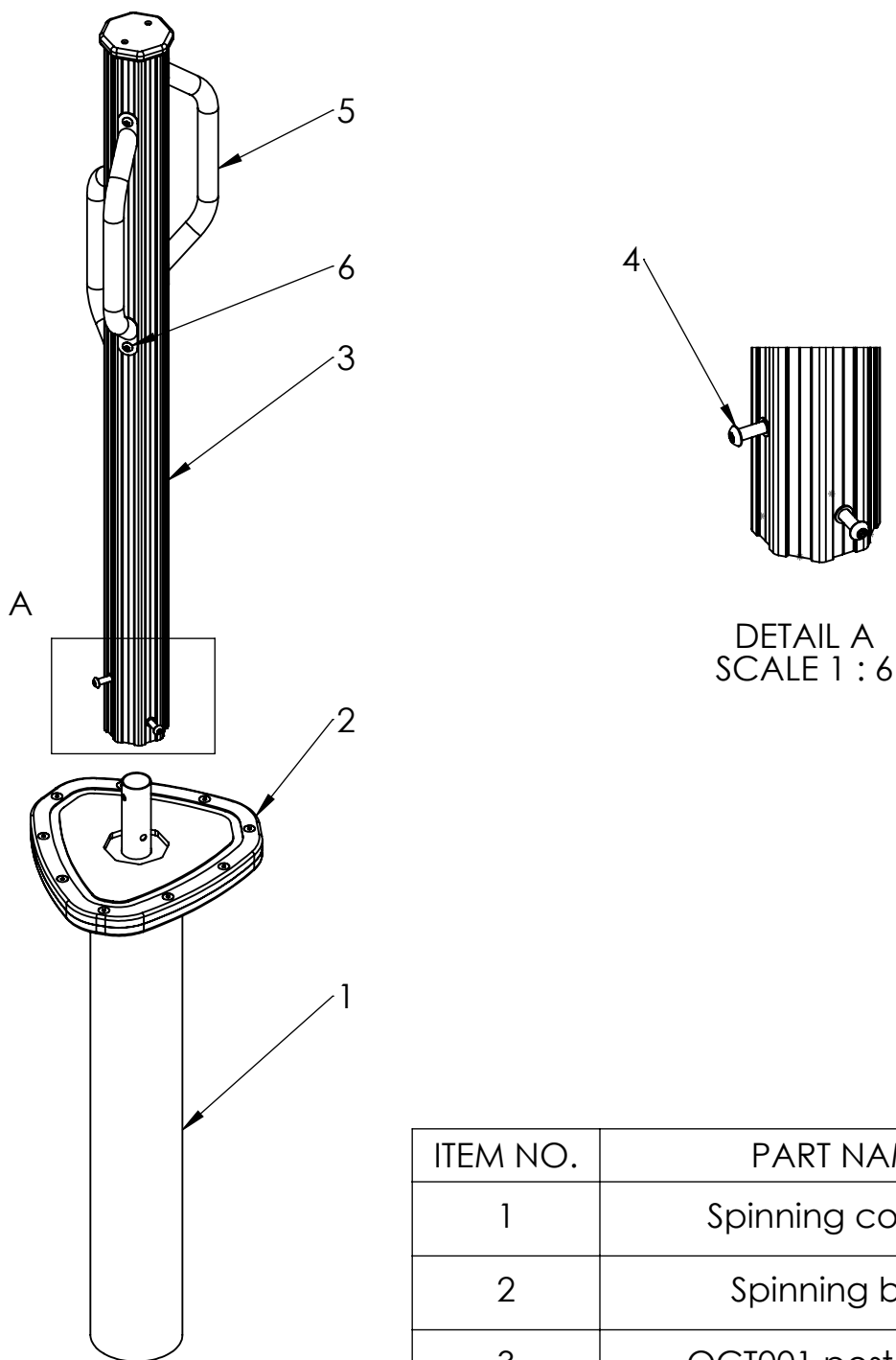

DETAIL A
SCALE 1 : 6

ITEM NO.	PART NAME	QTY.
1	Spinning console	1
2	Spinning base	1
3	OCT001 post L-1400	1
4	M10x40 TX-Pin 40 (DIN9121)	4
5	Handle	3
6	M10x20 TX-Pin 40 (DIN9121)	6

UNLESS OTHERWISE SPECIFIED:
DIMENSIONS ARE IN MILLIMETERS
WEIGHT ARE IN KILOGRAMM

PART NUMBER / DWG NO.:

OCT001

	NAME	SIGNATURE	DATE	REVISION
DRAWN	M. Kalamees		6/18/2019	
APPV'D				

DESCRIPTION:

Spinner

MATERIAL:

metal, plastic

A4

WEIGHT:

SCALE: 1:12

SHEET 4 OF 4



Tiptiptap OÜ

Tiptiptap OÜ
Veetorni 9,
Jüri alevik, Rae vald,
75301 Harjumaa